

COBHAM

Cobham Antenna Systems

Coaxial Cable Assemblies

The most important thing we build is trust



AIRBORNE

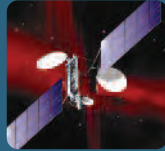

SPACE



SHIPBOARD



LABORATORY



Cobham Antenna Systems

YOUR MISSION-CRITICAL CABLE CONNECTION



In a mission-critical project, every component is critical to the mission—from the most complex semiconductor down to the last rivet. As a longtime supplier of microwave and radio frequency (RF) technology to the aerospace, defense and civilian industries, we at Cobham understand that better than anyone.

That's why we bring an uncompromising commitment to quality and performance to everything we build, including our coaxial cable assemblies.

- **Military and aerospace experience:** Cobham has been providing electronics to the Department of Defense and NASA for decades, fulfilling the most stringent requirements for performance and durability under the most extreme conditions. Our cable assemblies have flown on most military aircraft and NASA launch vehicles from the Atlas rocket to the space shuttle orbiters.
- **Quality and reliability:** At Cobham, we have the systems and processes in place to meet

your needs for ISO 9001:2000 and AS 9100:RevB certification, as well as defense standards. But we also pioneered the concept of "Design for Reliability," ensuring that reliability is built in—not added on—to every Cobham design using concurrent engineering, design, and development processes. Reliability engineering is engaged at the idea phase, and continues through full production and beyond.

- **Customization:** Cobham is the partner of choice when you need more than an "off-the-shelf" solution. We can work closely with you to design, engineer, and manufacture customized assemblies to your specifications—and deliver them on time.
- **Classified facility and hardware clearance:** With Cobham, even your most confidential projects remain closely-guarded secrets. Our facilities have classified clearance and we maintain rigorous security standards for your protection.

From advanced, lightweight cable assemblies to customized solutions, Cobham is your critical cable connection.

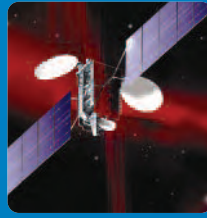

The export of some of the parts contained in this catalog is controlled by the U.S. Department of State and requires prior license approval.

Cobham has an on-going program of product improvement; specifications and designs are subject to change without notice.

Introduction

The Company	3
Products	4
The Catalog	5
Our Heritage	7
Markets	8
Manufacturing	9
Services	14

Product by Market Segment

Cable Selection Guide	17-21
Electronic Warfare	22-35
Airborne / Ground and Shipboard / Missiles	
Space	36-39
Laboratory	40-45
General Purpose / Test	
Commercial Aviation	46-47
Bulk OEM / Lightweight Assemblies	
Adapters	48-49
Special Purpose Products	50-54

Application Notes

Insertion Loss and VSWR Specifications	55
Connector Outline Dimensions	57
Power Handling	59
Recommendations for Cable Handling	62
Typical Environmental Tests	63

Ordering

Ordering Instructions	64
Selection Criteria	67
Typical Cable Assembly Constructions	70
Typical Connector Construction	71
Custom Cable Assembly Requirements	72

Appendix

Engineering Reference	inside back cover
-----------------------	-------------------

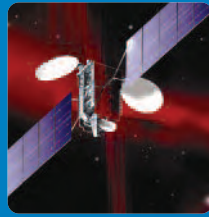

The extruder applies the primary moisture barrier made of various polymer materials

ANTENNA SYSTEMS**THE COMPANY****Cobham Cable Assemblies product line is part of Cobham Antenna Systems Microwave Components business unit, located in Exeter, New Hampshire**

We are a completely self-contained operation. We design and manufacture bulk cable and connectors, then assemble and test the finished products prior to shipping (for custom lengths) or for stocking in inventory (for select lengths of certain cable assemblies.) Our Exeter facility has the unique ability to perform qualification testing of cable assemblies at full rated power, high temperature, and high altitude simultaneously.

We have conducted thousands of qualification test programs to military and customer specifications. All necessary equipment is available on-site to test vibration (sine/random), shock (mechanical/thermal), temperature-altitude, humidity, salt fog, helium and vapor leak, and high CW/peak power in accordance with applicable specifications.

Cable assembly testing capabilities span the full range of needs, including flexure endurance, abrasion resistance, RF shielding effectiveness, and exposure to chemicals and fluids. All tests are performed to applicable mil specs of the U.S. Army, Navy, and Air Force, as well as NATO and other governments.

For the Next Generation... and Beyond

Cobham's proven ability to anticipate and fulfill industry needs for more than 50 years means you can always count on us to supply and qualify the reliable cable assemblies you need to support your next generation of systems and those beyond.



Cobham Antenna Systems

PRODUCTS

Cable Assemblies

DC to 50 GHz

Electronic Warfare

*Airborne
Ground & Shipboard
Missiles*

Space

Laboratory

*General Purpose
Test*

Commercial Aviation

*Bulk OEM
Lightweight Assemblies*

Special Applications

*500 different cable designs
5000 different connector
designs*

Cable assemblies developed and produced by Cobham cover broad frequency ranges from DC to 50 GHz, and are associated with operational ground-based, shipboard, airborne and space equipment.

Many different cable constructions have been developed including reduced loss, scuff resistant, high power, multi-conductor, reduced EMI, extra flexible and test types. Flexible cable sizes range from outer diameters of 0.050 inches (for missile gimbal applications) to 1.4 inches (for ground based communication systems.) All cables are designed and fabricated to ensure uniformity, consistency, and high quality. When we receive requirements for a new cable type, we can produce it quickly to specification.

Because we are able to design each cable connector required for the various cable assemblies, we can assure each customer of receiving the best combination of cable and connector characteristics for the specific application. Our in-house

cable design engineering staff custom-designs each connector interface to match the proper cable size and optimize finished assembly performance.

Our high performance airborne electronic warfare cable assemblies are so tough they must successfully endure 29 torturous environmental tests before receiving our seal of approval. Test extremes include 65G vibration, -65° to 200° C at 70,000 feet, and 100,000 flexures, to mention just a few. Very low loss and lightweight versions are also available.

Although we built our reputation for high-quality precision coaxial cable assemblies in the tough EW marketplace, we also provide them to non-defense and commercial markets.

For instance, our general purpose cable is an extremely durable, flexible cable that offers the same quality of workmanship, materials, and performance as our respected EW cable, but is designed to perform well in less-demanding environments.

ANTENNA SYSTEMS

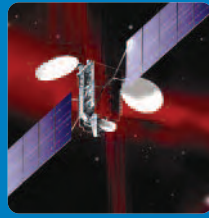

PRODUCTS/THE CATALOG

Smaller and lighter than MIL-DTL-17 cables, our rugged antenna mast cable assemblies are capable of continuous flexing in severe tactical environments—hot or cold. Compared to corrugated copper air-dielectric cables, our low loss, low VSWR mast cables can handle more than five times the CW power at one-half the minimum bend radius. Reelable in lengths up to several thousand feet, they can be easily unwound, deployed and rewound hundreds of times without degrading performance.

We've been selected by major air carriers to satisfy critical insertion loss and phase-match requirements for the FAA-mandated T-CAS (Traffic-Alert Collision Avoidance System) and MODE-S programs. Our T-CAS cable assemblies are manufactured to meet the same reliability and quality as our EW cables, yet offer the airlines the flexibility of field replaceable connector interfaces to eliminate costly "airplane-on-ground" (AOG) delays or flight cancellations.

Our phase-stable instrument test cable assemblies were the first to break the 40 GHz barrier. These special cables provide superior phase, amplitude, and VSWR stability for precise vector network analyzer testing. They meet spec even after being flexed 150,000 times—the equivalent of ten years of normal laboratory use! For general test applications, our durable, flexible general purpose test cables have field-replaceable interchangeable connector interfaces, and perform to 26.5 GHz.

The Catalog

All the cable types are outlined in the Selection Guide on pages 17-22 and described in detail in the individual data sections immediately following—arranged by product family. Application notes and other helpful information are included starting on page 55. The ordering section, starting on page 64, simplifies that task for you.

If you don't find exactly what you are looking for, please contact your field sales representative. The right solution for you may already exist in our extensive library of unique designs or we can custom-design a cable just for you.



The strander produces a uniform diameter stranded metal center conductor

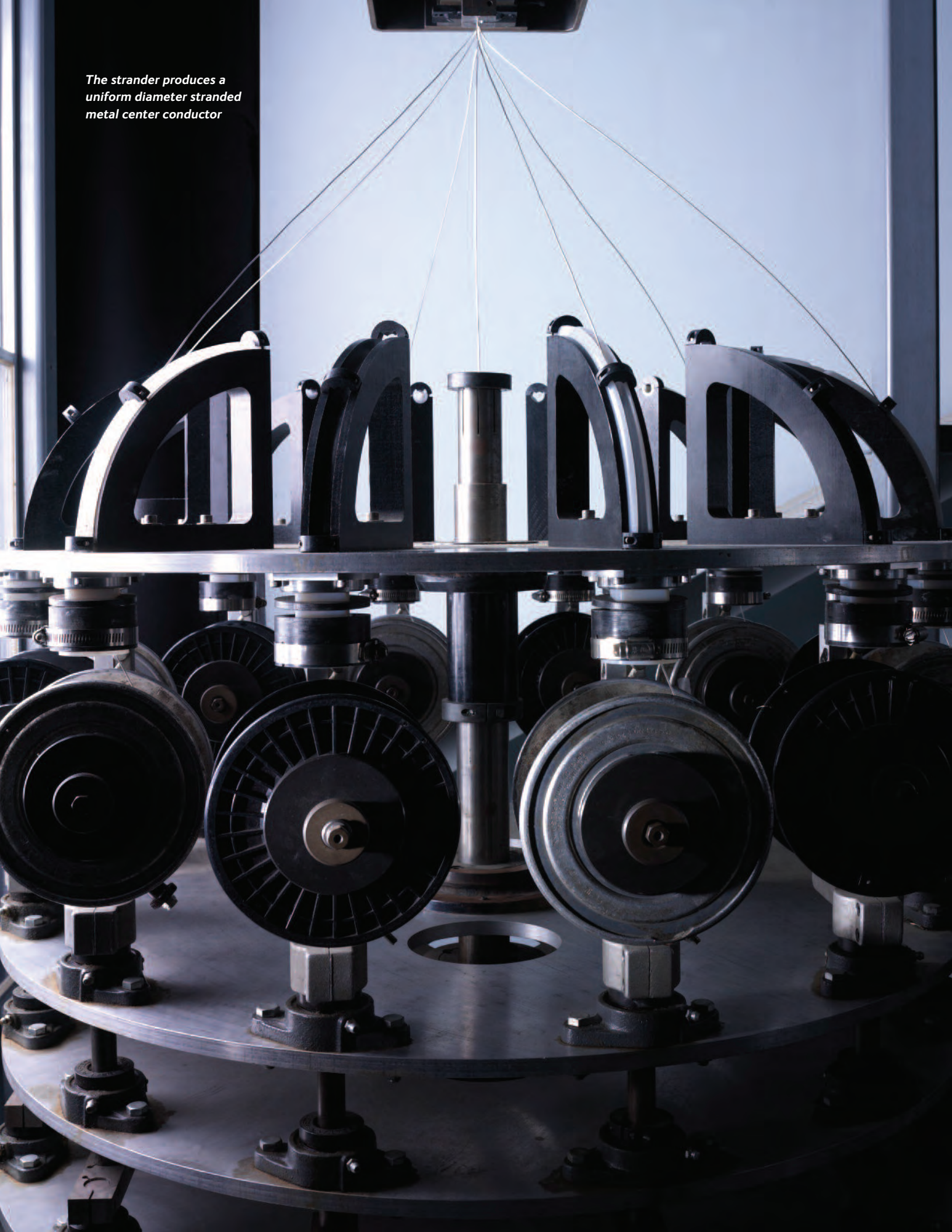

ANTENNA SYSTEMS



CABLE HERITAGE

	FA19 HFX	FA19 RX	FA29 RX	FN34 RX	FN25	FN35	FN40	FN55	FN61	FN35 RL	FN40 RL	FE56	FN50	FC-Z	FN24 RL	FN27 RL	FN31 RL	Custom Semi-Rigid
A-4							●											
A-6							●											
A-7							●											
A-10						●							●					
AC-130U					●		●			●	●							
AH-1-SJ																		
AH-64										●								
AV-8B						●												
AWACS						●												
B-1B					●	●		●										
B-52						●							●					
CH-47						●												
E-2C						●												●
EA-6B										●					●	●	●	
EF-111						●												
EP-3				●	●			●										
Eurofighter	●																	
F-4							●						●					
F-5						●												
F-8							●											
F-14A							●						●					
F-14D													●					
F-15							●											
F-15J				●														
F-16						●							●					
F-18				●		●				●								
FSX															●	●	●	
KC-10													●	●				
KC-135													●					
Mirage						●												
MPA	●	●	●						●									
P-3A					●	●							●					
-3B					●	●												
-3C					●	●												
Tornado					●	●							●					
T-45						●												
T-46A						●												
UH-1						●												
U2		●	●											●				
727														●				
737														●				
747														●				
757														●				
767														●				
777														●				
DC-9														●				
DC-10														●				
MD-11														●				
MD-80														●				
Trident II						●												
Delta III			●															
Delta IV				●														
Atlas V			●															
Sea Launch			●															

Cable Assemblies

DC to 50 GHz

Electronic Warfare

- Airborne
- Ground & Shipboard
- Missiles

Space

Laboratory

- General Purpose
- Test

Commercial Aviation

- Bulk OEM
- Lightweight Assemblies

Special Applications

500 different cable designs
5000 different connector designs

◀ Customers around the world select Cobham cables for their exacting defense or commercial applications. To the left is a partial list of platforms and programs:

ANTENNA SYSTEMS



MARKETS



Cobham has supplied cable products to a wide variety of markets for more than 50 years.

Our products continue to have a clear focus on military and high performance commercial applications as well as a long standing commitment to the space market. We would be pleased to provide the details of our Heritage experience upon request.

Cobham cable products are known for their excellent electrical performance, proven reliability and overall mechanical strength because these products provide the best cable to connection transitions available in the industry. Because we design and manufacture both cable and connectors, we can offer custom products that are designed for specific customer requirement.

This Catalog is organized around cable products for the specific market applications as shown below:

Electronic Warfare

- **Airborne**
 - High Performance
 - Very Low Loss
 - Lightweight
- **Ground and Shipboard**
- **Missiles and Precision Guided Weapons**

Space Laboratory

- **General Purpose**
 - Air-Spaced Teflon Dielectric
 - Solid Teflon Dielectric
- **Test**
 - 18 & 26.5 GHz
 - Phase Stable to 26.5 GHz
 - Phase Stable to 50 GHz

Commercial Aviation

- **Bulk OEM**
- **Lightweight Cable Assemblies**

Special Applications



The round braider produces round braid over first outer conductor for mechanical strength and additional shielding

ANTENNA SYSTEMS

MANUFACTURING

Cobham maintains a complete in-house cable assembly manufacturing capability and has been producing quality coaxial cable assemblies for more than 50 years.

To ensure high product quality, we design and manufacture our own bulk cable and connector piece parts that make up these cable assemblies. Our production department is equipped to produce more than 10,000 cable assemblies per month. The manufacturing process is closely monitored to ensure consistency of yield and to maintain the high quality that is synonymous with Cobham cables.

Over the years, we have developed a complete product line of high-performance coaxial cables ranging in size from 0.05 inch (1.27 mm) diameter FA05RX, a very flexible cable, to the large 1.40 inch (35.6 mm) diameter FE140 flexible cable with extremely low insertion loss for special ground-based applications.

Our extensive investment in capital equipment, combined with experienced operators and a dedicated engineering staff, provide a quick response capability. Thus, we can meet a wide range of cable assembly design and production requirements and deliver new types of cable in a relatively short period of time.

To maintain the excellent characteristics of our cable assemblies, we test and characterize each bulk cable lot utilizing our own special test equipment and facilities prior to placing them in inventory.

Since we design and manufacture the connectors required for the various cable assemblies, you're assured of receiving the best combination of cable and connector characteristics optimized for your application. Unique design features in our connectors provide superior electrical, mechanical and environmental performance. Our in-house machining operation provides a

high-quality, quick response source of connector piece parts. Whether you need a high-volume standard connector or small-volume custom connector, our complete in-house design and manufacturing can deliver them in a timely manner.

A critical step in building quality coaxial cable is the assembly of the connectors and cable. The connector/cable junction is key to maintaining excellent electrical and mechanical specifications. At Cobham, major emphasis is placed on providing tooling and procedures as well as training our assemblers in their proper use. In most cases, production personnel contribute directly to the development of these assembly aids.





We utilize precision state-of-the-art equipment to test all cable assemblies for swept VSWR and insertion loss. We have the capability to perform complete qualification testing to MIL-T-81490, MIL-DTL-87104, and customer-defined specifications. Upon request, we can provide actual measured insertion loss and VSWR data with each cable assembly. When considering different levels of acceptance testing, please be aware that the following alternatives can minimize total cable assembly costs:

1. Certification of sample testing—recorded data retained at Cobham.
2. Testing for VSWR and insertion loss at the maximum operating frequency only.

We have one of the largest collections of high-power signal sources in the U.S. for use in power-handling tests. These sources provide power levels to 10 kW, pulsed and CW, across the various frequency bands.

Our manufacturing test area has multiple computer controlled network analyzer systems that are used for the high volume measurements of VSWR, insertion loss, stability, phase and time delay at frequencies up to 50 GHz. These systems produce hard copies of the measured data in single or multiple trace formats. Each test set is capable of accurately measuring several hundred cable assemblies per week



ANTENNA SYSTEMS



MANUFACTURING

In-house Mil Spec Testing Capability

- Abrasion*
- Altitude*
- Concentrated Load*
- Connector Retention*
- Connector Torque*
- Corona*
- Flexure*
- Helium Leak Rate*
- High Potential*
- Humidity*
- Immersion (Altitude)*
- Impact Shock*
- Power Handling*
- Propagation Velocity*
- RF Leakage*
- Salt Fog*
- Temperature Cycle*
- Temperature/Altitude*
- Thermal Shock*
- Vapor Leakage*
- Vibration*

We have multiple high frequency, high accuracy network analyzers that operate up to 50 GHz. These computer controlled systems are used in a variety of production tests, including:

- VSWR
- Insertion Loss and Loss Matching
- Phase and Phase Matching
- Delay and Delay Matching
- Smith Charts
- Torque and Tensile Loads
- Temperature Testing
- Stability
- Uniformity

We also have Passive Inter-modulation Distortion (PIM) Test equipment covering 10 MHz to 20 GHz to measure any non-linearity in cable assemblies.



For phase matching, we maintain phase standards stored in computer memory. These standards are available online to permit phase matching at any time with historical reference to the original standard.

We can supply generic data or data per customer requirements for more specific needs.

Protective Packaging for Shipment

We package all cable assemblies to minimize possible damage in shipment. The cables are wrapped on or packed in a form to ensure that the minimum bend radius of the cable is not exceeded. This form is then laced in a durable carton for shipment.

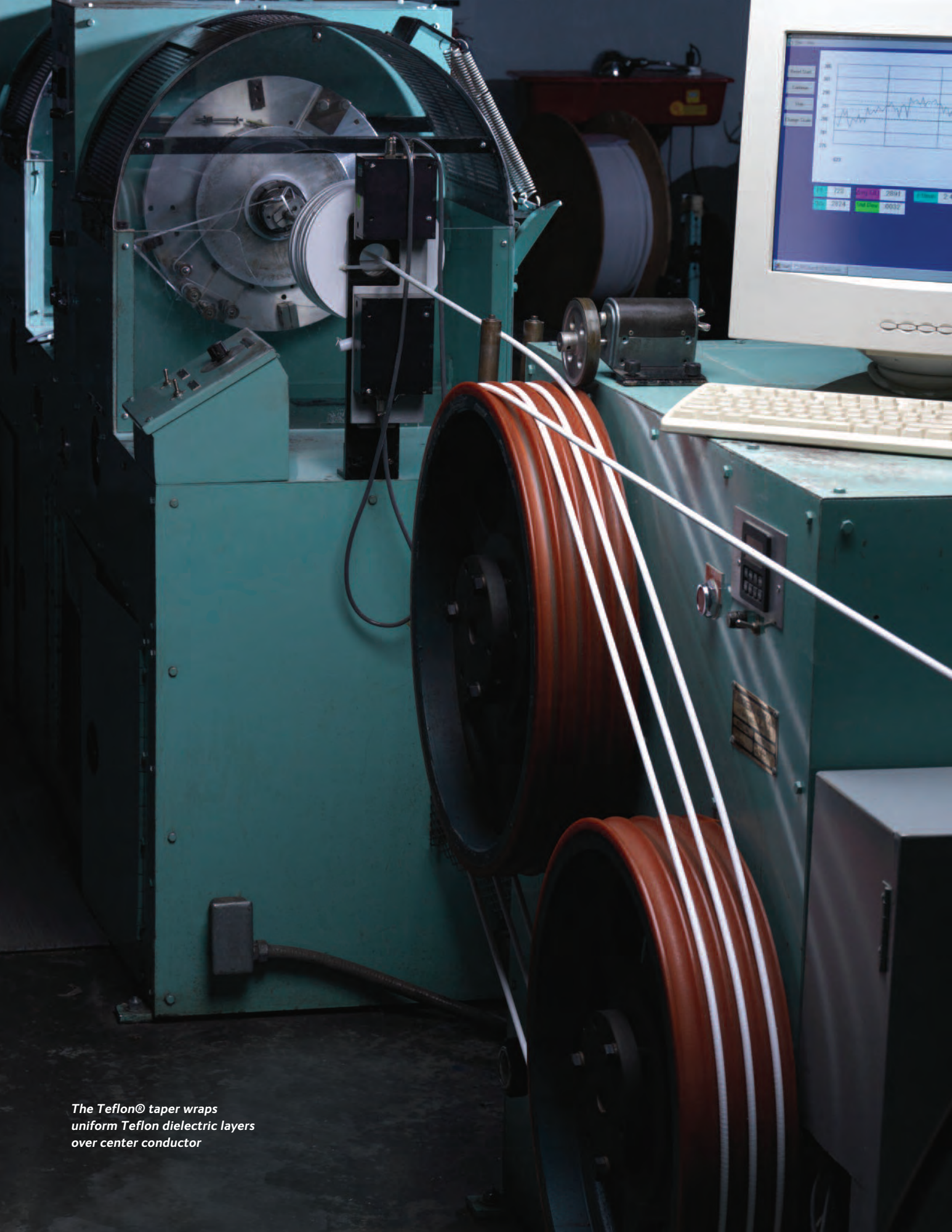

*The Teflon® taper wraps
uniform Teflon dielectric layers
over center conductor*

ANTENNA SYSTEMS

SERVICES

In-house Mil Spec Testing Capability

*Abrasion
Altitude
Concentrated Load
Connector Retention
Connector Torque
Corona
Flexure
Helium Leak Rate
High Potential
Humidity
Immersion (Altitude)
Impact Shock
Power Handling
Propagation Velocity
RF Leakage
Salt Fog
Temperature Cycle
Temperature/Altitude
Thermal Shock
Vapor Leakage
Vibration*

In addition to designing and manufacturing cable assemblies, Cobham offers a range of services that enhance our product offerings and fulfill special customer needs.

All services are performed at our secure facility, which is ITAR-protected and cleared for projects designated as Top Secret.

Applications Engineering

Our technical sales and engineering personnel are always available to discuss your applications requirements and make recommendations, within the boundaries of publically available information, for the best use of our cable, connectors, and RF components.

Prototype Capability

Our design engineers, using state-of-the-art software, serve as the foundation for our prototype

design system. With computers spread throughout our facility, our engineers can analyze previously obtained data and determine whether existing designs will satisfy your needs. Samples can then be manufactured to suit specific needs and supplied to you quickly. If new designs of connectors, bulk cable, or both are required, the computer system software would be used to aid in the design effort.

Should prototype quantities be required in less than the normal lead time, our production personnel will work with you to provide, on an expedited basis, the quantity of product you require.

The export of prototypes based on specific defense designs and applications is dependent on the approval of the U.S. Government Department of State and the provisions of the ITAR (International Traffic in Arms regulations).



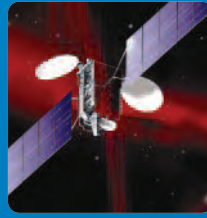

Mockup Assistance

Having provided numerous cable assembly mockups on the A-7, B-1B, EA-6B, F-14, F-15, F-18, U-2, AH-1, T-46, OV-1, P-3C, and various other aircraft, helicopters, and ships, we are prepared to provide mockup services at customer facilities on a few days notice. Mockup assistance may include Cobham accepting complete responsibility for determining cable type, connector configurations, cable assembly lengths, cable routing, recommending installation procedures, electrical/mechanical specifications, and testing procedures.

Qualification Testing

Without the right partner, qualification testing of cable assembly programs can be an extensive and costly process. However, in the

hands of experienced personnel with access to readily-available facilities, it can be both economical and efficient. Cobham has that experience and those facilities. Our people are intimately familiar with MIL-T-81490, MIL-DTL-87104, and customer specifications. All necessary equipment is available within our facility, including a wide variety of vitally-important high-power test equipment.

Program Management

Since we have participated in many of the largest defense and non-defense programs, we maintain the complete program management capability necessary to successfully complete development and manufacture of product for major programs.



*The Nomex® braider braids
a rugged outer jacket of colored
Nomex material over the
taped cable*



Cable Naming Convention

Cobham offers a wide variety of cable constructions to fit numerous applications. A great deal of information is contained in the cable name. The cable naming convention is presented below. Please contact the factory if the cable you need isn't in the in this catalog.

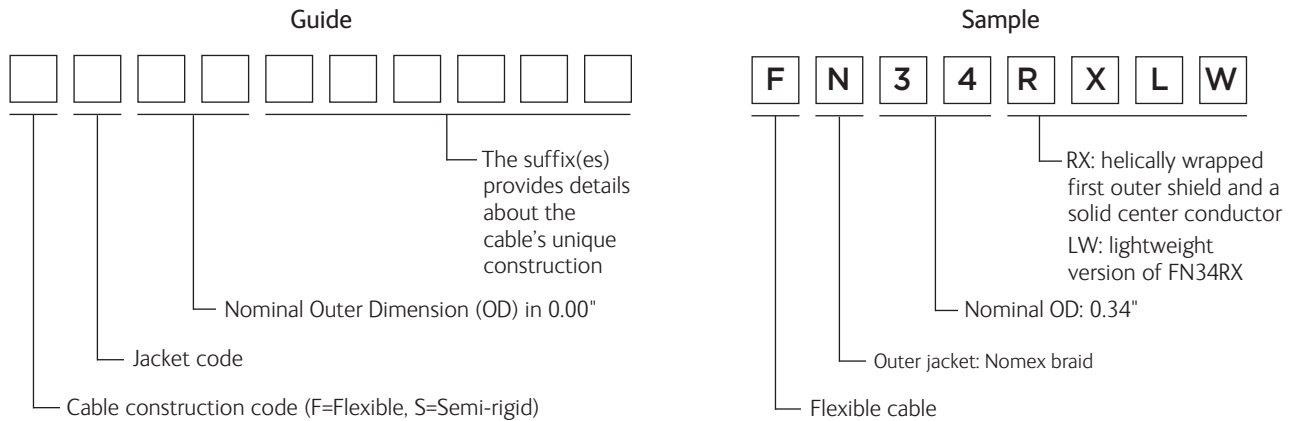

<p>Available Jackets include: A — PFA Teflon C — FEP Teflon E — Elastomer (Polyurethane or Polyolefin) N — Nomex S — Silicone Z — Tefzel</p> <p>Note: Not all jackets are available on every core.</p>	<p>Some of the more common suffixes are: Blank (no suffix) — Stranded center conductor RL (Reduced Loss) — Solid center conductor X — Helicly wrapped first outer shield RX — Both helicly wrapped first shield and solid center conductor LW — Lightweight version (often aluminum conductors) WW — Wirewound steel crush resistance layer SQ — Space Qualified TX — Thermal Treated RX construction</p> <p>Note: Not all suffixes are included here. Some suffixes are combined as in FN34RXLW, the lightweight version of FN34RX cable.</p>
----------------------------------------------------------------------------------------------------------------------------------------------------------------------------------------------------------------------------------------------------------------------------------------------------------------------------------------------------	--------------------------------------------------------------------------------------------------------------------------------------------------------------------------------------------------------------------------------------------------------------------------------------------------------------------------------------------------------------------------------------------------------------------------------------------------------------------------------------------------------------------------------------------------------------------------------------------------------------------------------------------------------------------------------------------------------------------------------------

Depending on your application, you may have identified the maximum insertion loss that your system will tolerate, or you may have a size or weight limit. Use these facts to select the cable types most suitable for your needs. If you need assistance, please complete the Custom Cable Assembly Requirements form (page 72) and contact us.

Maximum Insertion Loss: dB/100 ft.

Cable Type	OD (in)	Jacket Mat	Wgt (lb/ft)	F _{co} (GHz)	Fass'y (GHz)	0.1 GHz	1 GHz	2 GHz	4 GHz	8 GHz	12 GHz	18 GHz	26.5 GHz	40 GHz	App Code
FA05LX	0.05	PFA	0.004	130	18	18	54.2	76.8	108.8	154.3	189.5	232.7			LL, G, M, S
FA07LX	0.07	PFA	0.0065	100	18	10	30.2	42.8	60.8	86.5	106.3	130.9			LL, G, M, S
FC07SZ	0.07	FEP	0.005	50	10	9.7	29.4	41.7	59.4	84.9					G, CA, M
FT08	0.08	PTFE	0.0064	50	3	10.7	32.3	45.8							M, SP
FA09HFX	0.09	PFA	0.0105	65	18	8.7	26.2	37.2	52.8	75.1	92.5	113.9			M
FA09LX	0.09	PFA	0.01	65	20	7.2	21.8	30.9	44	62.7	77.2	95.2			LL, G, M, S
FA09X	0.09	PFA	0.0104	65	18	8.7	26.2	37.2	52.8	75.1	92.5	113.9			SP, G, M, S
FC09Z	0.09	FEP	0.0081	50	10	9.3	28.2	40	57	81.5					CA
FG09	0.09	TGF	0.0076	74	18	9.7	29.4	41.7	59.4	84.9	104.8	129.5			M, SP
FZ09LX	0.09	Tefzel	0.0106	65	18	7.2	21.8	30.9	44	62.7	77.2	95.2			M, S
FZ09LXW	0.09	Tefzel	0.0106	65	18	7.2	21.8	30.9	44	62.7	77.2	95.2			M, S
FE10ST	0.1	PST	0.0085	74	18	9.7	29.4	41.7	59.4	84.9	104.8	129.5			G

Legend	CA = Commercial Aviation	LL = Low Loss	SP = Special Purpose	FEP = DuPont Teflon TEP
	G = General	LW = Light Weight	T = Test	ETFE = DuPont Tefzel ETFE
	GR/SH = Ground/Ship	M = Missile	Jacket Materials:	Siltem = Siloxane PEI Block Copolymer (GE)
	HP = High Performance	S = Space	PFA = DuPont™ Teflon® PFA	Nomex = m-Aramid fiber (GE)

Depending on your application, you may have identified the maximum insertion loss that your system will tolerate, or you may have a size or weight limit. Use these facts to select the cable types most suitable for your needs. If you need assistance, please complete the Custom Cable Assembly Requirements form (page 72) and contact us.

Maximum Insertion Loss: dB/100 ft.

Cable Type	OD (in)	Jacket Mat	Wgt (lb/ft)	F _{CO} (GHz)	Fass'y (GHz)	0.1 GHz	1 GHz	2 GHz	4 GHz	8 GHz	12 GHz	18 GHz	26.5 GHz	40 GHz	App Code
FC11Z	0.11	FEP	0.0123	50	10	6.7	20.4	29	41.4	59.4					CA
FA12RX ▲	0.12	PFA	0.0138	50	50	4.3	13.1	18.6	26.6	38.1	47.2	58.6	72.3	90.6	LL, G, S, M
FA12X	0.12	PFA	0.0135	50	26.5	4.8	14.6	20.7	29.6	42.4	52.4	65	80		SP, G, S, M
FE12RL*	0.12	PST	0.014	50	50	6.2	18.9	26.9	38.5	55.2	68.4	84.9	104.7	131.2	G, T
FE12ST**	0.12	PST	0.014	50	50	6.8	20.6	29.3	41.8	60	74.3	92.2	113.7	142.2	G
FN12TF**	0.12	Nomex	0.014	50	50	6.8	20.6	29.3	41.8	60	74.3	92.2	113.6	142.2	SP, G
FZ12RX	0.12	Tefzel	0.0138	50	26.5	4.3	13.1	18.6	26.6	38.1	47.2	58.6	72.3		S, M
FC14Z	0.14	FEP	0.0198	40	10	4.8	14.6	20.8	29.8	43					CA
FN11Z	0.14	Nomex	0.018	50	10	6.7	20.4	29	41.4	59.4					SP, CA
FA15RX	0.15	PFA	0.02	40	40	3.4	10.3	14.6	21	30.2	37.5	46.7	57.8	72.9	LL, G, S
FA15X	0.15	PFA	0.0197	40	18	3.6	11.1	15.8	22.6	32.5	40.3	50.1			SP, G, S
FC15EX	0.15	FEP	0.0284	35	18	4.5	14.3	20.7	30.5	45.5	58.1	74.6			SP, G
FE15ST	0.15	PST	0.022	40	40	5.4	16.4	23.3	33.4	48.1	59.7	74.4	91.8	115.6	G
FN15RX	0.15	Nomex	0.0195	40	18	4.3	13.1	18.6	26.6	38.1	47.2	58.6	72.3		LL, S
FN15X	0.15	Nomex	0.0193	50	26.5	4.8	14.6	20.7	29.6	42.4	52.4	65	80		SP
FN15TF	0.16	Nomex	0.025	40	40	5.4	16.4	23.3	33.4	48.1	59.7	74.4	91.9	115.6	SP
FC17EX	0.17	FEP	0.037	30	18	3.8	12.2	17.7	26.2	39.4	50.5	65.1			SP, G
FN14Z	0.17	Nomex	0.028	40	10	4.8	14.6	20.8	29.8	43					CA
FN17EX	0.17	Nomex	0.0275	35	18	4.5	14.3	20.7	30.5	45.5	58.1	74.6			SP, G
FA19	0.18	PFA	0.032	26.5	26.5	3.4	10.4	14.9	21.4	31.2	39	48.9	61		SP, G
FG18	0.18	TGF	0.032	26.5	18	3.4	10.4	14.9	21.4	31.2	39	48.9			S, M, SP
FN18RL	0.18	Nomex	0.0261	40	18	4.1	12.7	18	25.9	37.5	46.8	58.5			LL
FN18RX	0.18	Nomex	0.0287	40	40	3.4	10.3	14.6	21	30.2	37.5	46.7	57.8	72.9	LL, S
FA19HFX	0.19	PFA	0.029	30	18	3.2	9.6	13.7	19.7	28.5	35.4	44.1			SP, G, M
FA19MX	0.19	PFA	0.029	30	18	3.2	9.6	13.7	19.7	28.5	35.4	44.1			SP, G, M
FA19RX	0.19	PFA	0.033	30	26.5	2.4	7.5	10.7	15.4	22.3	27.8	34.9	43.4		LL, G, S
FA19RXLW	0.19	PFA	0.0232	30	26.5	2.4	7.5	10.7	15.4	22.3	27.8	34.9	43.4		G, S
FA19TX	0.19	PFA	0.033	30	26.5	2.8	8.5	12.2	17.5	25.3	31.6	39.4			G, S
FA19X	0.19	PFA	0.032	30	26.5	2.7	8.2	11.8	17	24.5	30.6	38.3	47.5		SP, G, S
FE19	0.19	PU	0.032	26.5	26.5	3.4	10.4	14.9	21.4	31.2	39	48.9	60.9		G, T
FE19LSX	0.19	Siltem	0.032	30	26.5	2.7	8.3	11.8	17	24.5	30.6	38.3	47.5		GR/SH, SP
FE19RL	0.19	PST	0.033	26.5	26.5	3	9.3	13.3	19.3	28.1	35.3	44.4	55.5		G, T
FE19ST	0.19	PST	0.032	26.5	26.5	3.4	10.4	14.9	21.4	31.2	39	48.9	60.9		G
FN19EX	0.19	Nomex	0.0394	30	18	3.8	12.2	17.7	26.2	39.4	50.5	65.1			SP, G
FN19TF	0.19	Nomex	0.032	26.5	26.5	3.4	10.4	14.9	21.4	31.2	39	48.9	61		SP

▲50 GHz = 102.5 *50 GHz = 148.5 **50 GHz = 160.8

18	Legend	CA = Commercial Aviation	LL = Low Loss	SP = Special Purpose	FEP = DuPont Teflon TEP
		G = General	LW = Light Weight	T = Test	ETFE = DuPont Tefzel ETFE
		GR/SH = Ground/Ship	M = Missile	Jacket Materials:	Siltem = Siloxane PEI Block Copolymer (GE)
		HP = High Performance	S = Space	PFA = DuPont™ Teflon® PFA	Nomex = m-Aramid fiber (GE)

Depending on your application, you may have identified the maximum insertion loss that your system will tolerate, or you may have a size or weight limit. Use these facts to select the cable types most suitable for your needs. If you need assistance, please complete the Custom Cable Assembly Requirements form (page 72) and contact us.

Maximum Insertion Loss: dB/100 ft.

Cable Type	OD (in)	Jacket Mat	Wgt (lb/ft)	F _{CO} (GHz)	Fass'y (GHz)	0.1 GHz	1 GHz	2 GHz	4 GHz	8 GHz	12 GHz	18 GHz	26.5 GHz	40 GHz	App Code
FZ19RX	0.19	Tefzel	0.033	30	26.5	2.4	7.5	10.7	15.4	22.3	27.8	34.9	43.4		S
FZ19TX	0.19	Tefzel	0.033	30	28	2.8	8.5	12.2	17.5	25.3	31.6	39.4			S
FC20	0.19	FEP	0.04	28	18	3.2	9.8	14	20.2	29.4	36.8	46.3			G
FC20RZ	0.19	FEP	0.043	28	10	3.1	9.7	13.9	20	29.2					CA
FC20Z	0.19	FEP	0.039	28	10	3.2	9.8	14	20.2	29.4					CA
FA20RX	0.2	PFA	0.0389	28	26.5	2.2	6.8	9.7	14.1	20.4	25.6	32.1	40.1		LL, G, S
FA20RXLW	0.2	PFA	0.0273	28	26.5	2.2	6.8	9.7	14.1	20.4	25.6	32.1	40.1		LW
FC21RL	0.21	FEP	0.0526	26.5	18	2.3	7.3	10.5	15.2	22.4	28.2	35.8			G
FN20Z	0.21	Nomex	0.045	28	10	3.2	9.8	14	20.2	29.4					G, CA
TRX21	0.21	Nomex	0.0352	60	18	9.5	29.7	42.6	62	91.2	115	145.8			SP
FA22RX	0.22	PFA	0.047	24	18	2	6.3	9	13	18.9	23.7	29.8			LL, G
FA22RXWW	0.22	PFA	0.0528	30	26.5	2.5	7.7	11	18.8	22.9	28.6	35.8	44.6		LL, G
FC22	0.22	FEP	0.0484	23.5	18	2.6	8.1	11.5	16.7	24.5	30.8	38.9			G
FN22	0.22	Nomex	0.04	28	18	3.2	9.8	14	20.2	29.4	36.8	46.3			SP
FN22RX	0.22	Nomex	0.042	30	26.5	2.4	7.5	10.7	15.4	22.3	27.8	34.9	43.4		LL, S
FN22RXM	0.22	Nomex	0.042	30	26.5	2.4	7.5	10.7	15.4	22.3	27.8	34.9	43.4		LL
FN22TX	0.22	Nomex	0.042	30	18	2.8	8.5	12.2	17.5	25.3	31.6	39.4			S
FN22X	0.22	Nomex	0.043	30	26.5	2.7	8.3	11.8	17	24.5	30.6	38.3	47.5		SP, S
FN22XM	0.22	Nomex	0.043	30	26.5	2.7	8.3	11.8	17	24.5	30.6	38.3	47.5		SP
FS23MX	0.23	Silicone	0.043	30	18	3.2	9.6	13.7	19.7	28.5	35.4	44.1			M, SP
ITC23	0.23	Nomex	0.05	30	26.5	3.8	12.2	17.7	26.2	39.4	50.5	65.1			T
FN24	0.24	Nomex	0.051	26.5	26.5	2.8	8.5	12.2	17.7	25.9	32.5	41	51.4		SP
FN24G	0.24	Nomex	0.051	26.5	26.5	2.8	8.5	12.2	17.7	25.9	32.5	41	51.4		T
FN24RL	0.24	Nomex	0.0525	26.5	26.5	2.5	7.9	11.3	16.4	24	30.2	38.2	48		LL
FA25RX	0.25	PFA	0.058	20	18	1.8	5.6	8	11.6	16.9	21.2	26.8			LL, G, S
FC28Z	0.25	FEP	0.0706	21	10	2.5	7.7	11.1	16.1	23.6					CA
FE25	0.25	PU	0.05	23	18	2.8	8.8	12.6	18.2	26.6	33.4	42.1			G, T
FN25	0.25	Nomex	0.055	23.5	18	2.6	8.1	11.5	16.7	24.5	30.8	38.9			SP
FN25G	0.25	Nomex	0.055	23.5	18	2.6	8.1	11.5	16.7	24.5	30.8	38.9			T
FN25RXWW	0.25	Nomex	0.0616	30	26.5	2.5	7.7	11	15.8	22.9	28.6	35.8	44.6		LL, G
FE26RX	0.26	PU	0.06	24	18	2	6.3	9	13	18.9	23.7	29.8			GR/SH
FE26X	0.26	PU	0.0512	24	18	2.2	6.8	9.7	14	20.4	25.5	32			GR/SH
FN26RX	0.26	Nomex	0.0583	24	18	2	6.3	9	13	18.9	23.7	29.8			LL
FE27RXBR	0.27	PU	0.0645	24	18	2	6.3	9	13	18.9	23.7	29.8			GR/SH
FN27R	0.27	Nomex	0.083	21	18.2	2	6.3	9.1	13.3	19.7	24.9	31.7			LL
FN28Z	0.28	Nomex	0.076	21	10	2.5	7.7	11.1	16.1	23.6					CA

Legend

CA = Commercial Aviation
 G = General
 GR/SH = Ground/Ship
 HP = High Performance

LL = Low Loss
 LW = Light Weight
 M = Missile
 S = Space

SP = Special Purpose
 T = Test

Jacket Materials:
 PFA = DuPont™ Teflon® PFA

FEP = DuPont Teflon TEP
 ETFE = DuPont Tefzel ETFE
 Siltem = Siloxane PEI Block Copolymer (GE)
 Nomex = m-Aramid fiber (GE)

Depending on your application, you may have identified the maximum insertion loss that your system will tolerate, or you may have a size or weight limit. Use these facts to select the cable types most suitable for your needs. If you need assistance, please complete the Custom Cable Assembly Requirements form (page 72) and contact us.

Maximum Insertion Loss: dB/100 ft.

Cable Type	OD (in)	Jacket Mat	Wgt (lb/ft)	F _{co} (GHz)	F _{ass'y} (GHz)	0.1 GHz	1 GHz	2 GHz	4 GHz	8 GHz	12 GHz	18 GHz	26.5 GHz	40 GHz	App Code
HTS28	0.28	Nomex	0.08	26	18	2.8	8.7	12.5	18.1	26.4	33.1	41.7			SP
FA29RX	0.3	PFA	0.083	18	18	1.4	4.3	6.2	8.9	12.8	16	20			LL, G, S
FA29X	0.3	PFA	0.081	18	18	1.6	4.9	7	10.1	14.5	18.1	22.5			SP, G
FA31TX	0.3	PFA	0.083	18	18	1.6	4.9	7	10	14.5	18	22.5			S
FN30	0.3	Nomex	0.0801	20	18	2.2	7	10.1	14.6	21.6	27.2	35			SP
FZ31RX	0.3	Tefzel	0.083	18	18	1.4	4.3	6.2	8.9	12.8	16	20			S
FZ31RXW	0.3	Tefzel	0.083	18	18	1.4	4.3	6.2	8.9	12.8	16	20			S
FZ31TXW	0.3	Tefzel	0.083	18	18	1.6	4.9	7	10	14.5	18	22.5			S
FA31RXLW	0.31	PFA	0.0651	18	18	1.4	4.3	6.2	8.9	12.8	16	20			LW, G, S
FC32	0.31	FEP	0.1	18	18	2	6.2	8.9	13	19.2	24.3	31			G, T
FN31RX	0.31	Nomex	0.0846	18.5	18	1.4	4.3	6.2	8.9	12.8	16	20			LL
FN31X	0.31	Nomex	0.0846	18.5	18	1.7	5.1	7.4	10.6	15.5	19.4	24.5			SP
FC38RZ	0.32	FEP	0.113	16	10	1.5	4.7	6.8	10	15					CA
FC38Z	0.32	FEP	0.1127	16	10	1.7	5.3	7.6	11.2	16.7					CA
FE32LSX	0.32	Siltem	0.081	18	18	1.6	4.9	7	10.1	14.5	18.1	22.5			GR/SH, SP
FN32RL	0.32	Nomex	0.1023	18.2	18.2	1.7	5.4	7.8	11.4	17	21.6	27.7			LL
FN32RX	0.32	Nomex	0.091	18.5	18.2	1.6	4.9	7	10.1	14.7	18.4	23			LL
FA34RXLWWW	0.34	PFA	0.0965	18	18	1.5	4.5	6.4	9.1	13.2	16.4	20.5			LW, G
FA34RXWW	0.34	PFA	0.1285	18	18	1.5	4.5	6.4	9.1	13.2	16.4	20.5			LL, G
FE34RX	0.34	PU	0.101	18	18	1.4	4.3	6.2	8.9	12.8	16	20			GR/SH
FN34RX	0.34	Nomex	0.101	18	18	1.4	4.3	6.2	8.9	12.8	16	20			LL, S
FN34RXLW	0.34	Nomex	0.0714	18	18	1.4	4.3	6.2	8.9	12.8	16	20			LW, CA, S
FN34RXLWM	0.34	Nomex	0.0714	18	18	1.4	4.3	6.2	8.9	12.8	16	20			LW
FN34RXM	0.34	Nomex	0.101	18	18	1.4	4.3	6.2	8.9	12.8	16	20			LL
FN34TX	0.34	Nomex	0.101	18	18	1.6	4.9	7	10	14.5	18	22.5			S
FN34X	0.34	Nomex	0.102	18	18	1.6	4.9	7	10.1	14.5	18.1	22.5			SP, G
FN38Z	0.34	Nomex	0.117	18	10	1.7	5.3	7.6	11.2	16.7					CA
FE35	0.35	PU	0.1084	18	18	2	6.2	8.9	13	19.2	24.3	31			GR/SH
FE35RL	0.35	PU	0.1084	18	18	1.5	4.8	6.9	10.2	15.2	19.4	25			GR/SH
FE35RLM	0.35	PU	0.1084	18	18	1.5	4.8	6.9	10.2	15.2	19.4	25			GR/SH
FE35RXBR	0.35	PU	0.1071	18	18	1.4	4.3	6.2	8.9	12.8	16	20			GR/SH
FN35	0.35	Nomex	0.099	18	18	2	6.2	8.9	13	19.2	24.3	31			SP
FN35G	0.35	Nomex	0.099	18	18	2	6.2	8.9	13	19.2	24.3	31			T
FN35RL	0.35	Nomex	0.101	18	18	1.5	4.8	6.9	10.2	15.2	19.4	25			LL
FN37	0.37	Nomex	0.111	18	18	2	6.3	9.1	13.2	19.6	24.8	31.5			SP
FN37RXWW	0.37	Nomex	0.1326	18	18	1.5	4.5	6.4	9.1	13.2	16.4	20.5			LL

Legend

CA = Commercial Aviation
 G = General
 GR/SH = Ground/Ship
 HP = High Performance

LL = Low Loss
 LW = Light Weight
 M = Missile
 S = Space

SP = Special Purpose
 T = Test
Jacket Materials:
 PFA = DuPont™ Teflon® PFA

FEP = DuPont Teflon TEP
 ETFE = DuPont Tefzel ETFE
 Siltem = Siloxane PEI Block Copolymer (GE)
 Nomex = m-Aramid fiber (GE)

Depending on your application, you may have identified the maximum insertion loss that your system will tolerate, or you may have a size or weight limit. Use these facts to select the cable types most suitable for your needs. If you need assistance, please complete the Custom Cable Assembly Requirements form (page 72) and contact us.

Maximum Insertion Loss: dB/100 ft.

Cable Type	OD (in)	Jacket Mat	Wgt (lb/ft)	F _{co} (GHz)	F _{ass'y} (GHz)	0.1 GHz	1 GHz	2 GHz	4 GHz	8 GHz	12 GHz	18 GHz	26.5 GHz	40 GHz	App Code
FN40	0.37	Nomex	0.12	16.5	16.5	1.7	5.3	7.6	11.2	16.7	21.2				SP
FN40RL	0.37	Nomex	0.12	16.5	16.5	1.5	4.7	6.8	10	15	19.2				LL
HTS38	0.38	Nomex	0.1688	18	18	1.9	5.8	8.4	12.3	18.3	23.2	29.6			SP
FN35WW	0.4	Nomex	0.154	18	18	2	6.2	8.9	13	19.2	24.3	31			SP
FA46RX	0.46	PFA	0.188	11	9	1	3.1	4.5	6.5	9.7					LL, G, S
FA46RXLW	0.46	PFA	0.131	11	9	1	3.1	4.5	6.5	9.7					LW, G, S
FE47	0.47	PU	0.1744	13	13	1.4	4.4	6.4	9.4	14.2	18.2				GR/SH
FZ47RX	0.47	Tefzel	0.188	8	8	1	3.1	4.5	6.5	9.7					S
FZ47RXW	0.47	Tefzel	0.188	8	8	1	3.1	4.5	6.5	9.7					S
FZ47TX	0.47	Tefzel	0.188	8	8	1.1	3.4	4.9	7.1	10.5					S
FZ47TXW	0.47	Tefzel	0.188	8	8	1.1	3.4	4.9	7.1	10.5					S
FN50V	0.48	Nomex	0.2003	12	6	1.5	4.8	6.9	10.3	15.5	19.9				SP
FC48Z	0.49	FEP	0.23	10	10	1	3.4	5	7.4	11.4					CA
FN49RX	0.49	Nomex	0.218	11	9	1	3.1	4.5	6.5	9.7					LL, S
FN49RXLW	0.49	Nomex	0.1678	11	9	1	3.1	4.5	6.5	9.7					LW
FC49	0.5	FEP	0.234	10	10	1	3.4	5	7.4	11.4					SP, G
FN50	0.5	Nomex	0.2	12	12	1.4	4.3	6.3	9.3	14					SP
FN48Z	0.52	Nomex	0.2487	10	10	1	3.4	5	7.4	11.4					CA
FN52RL	0.52	Nomex	0.239	10.5	10.5	1	3.2	4.6	6.8	11.6					LL
FN52RLLW	0.52	Nomex	0.184	10.5	10.5	1	3.2	4.6	6.8	11.6					LW
HTS53	0.53	Nomex	0.2213	12	12	1.4	4.3	6.3	9.3	14	18				SP
FE54RX	0.54	PU	0.227	8	8	1	3.1	4.5	6.5	9.7					GR/SH
FE55RXBR	0.55	PU	0.2354	8	8	1	3.1	4.5	6.5	9.7					GR/SH
FN55	0.55	Nomex	0.25	10	10	1	3.2	4.7	7.1	10.3					SP
FE56	0.56	PU	0.24	10	10	1	3.2	4.7	7.1	10.9					GR/SH
FN61	0.61	Nomex	0.31	8	8	1	3.1	4.5	6.6	9.8					SP
FE81	0.81	PU	0.5	6	6	0.7	2.3	3.3	5.1						GR/SH
FN87KR	0.87	Nomex	0.667	5	5	0.6	1.8	2.6	4						LL
FE92	0.92	PU	0.65	5	5	0.6	2	2.9	4.5						GR/SH
FN92TF	0.92	Nomex	0.65	5	5	0.6	2	2.9	4.5						SP
FN98V	0.98	Nomex	0.7055	5	5	0.6	2	2.9	4.5						SP
FN100KR	0.99	Nomex	0.883	4	4	0.5	1.6	2.3	3.5						LL
FE140	1.4	PU	1.4	3	3	0.5	1.5	2.2							GR/SH

A free cable design program CD is available that will provide all performance calculations automatically.

Legend	CA = Commercial Aviation	LL = Low Loss	SP = Special Purpose	FEP = DuPont Teflon TEP
	G = General	LW = Light Weight	T = Test	ETFE = DuPont Tefzel ETFE
	GR/SH = Ground/Ship	M = Missile	Jacket Materials:	Siltem = Siloxane PEI Block Copolymer (GE)
	HP = High Performance	S = Space	PFA = DuPont™ Teflon® PFA	Nomex = m-Aramid fiber (GE)

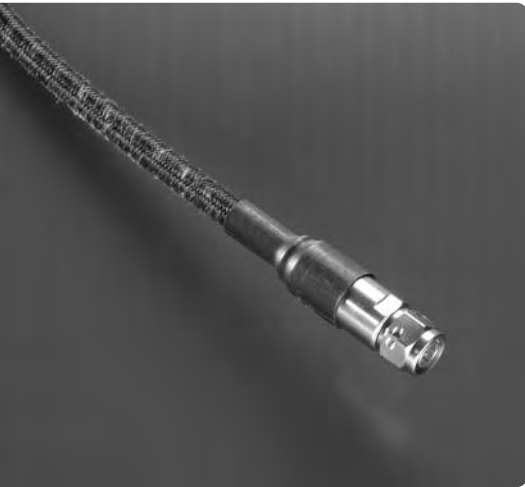

Long-term survivability in harsh environments

Many applications—especially airborne EW—require a cable assembly that can withstand a broad range of harsh environmental hazards and still provide a high-quality RF/microwave interconnect over a long period of time. Our high performance cable assemblies, designed specifically to survive in these environments, offer the optimum in electrical, mechanical, and environmental specifications to meet the most demanding applications.

MIL-T-81490 and MIL-DTL-87104 define a series of rigorous requirements for a coaxial cable assembly acceptable to the military in critical EW applications. A total of 29 unique tests, including vibration, chemical exposure, abrasion resistance, and connector retention are performed to qualify our high performance cable assemblies.

Connectors

A broad selection of popular connector interface styles is available for these cable types. To ensure your cable assembly performs to specifications, these high-quality connectors provide low VSWR and excellent cable/connector retention characteristics.

See pages 56-58 for a selection of typical connector outline dimensions.

Construction details for FN--

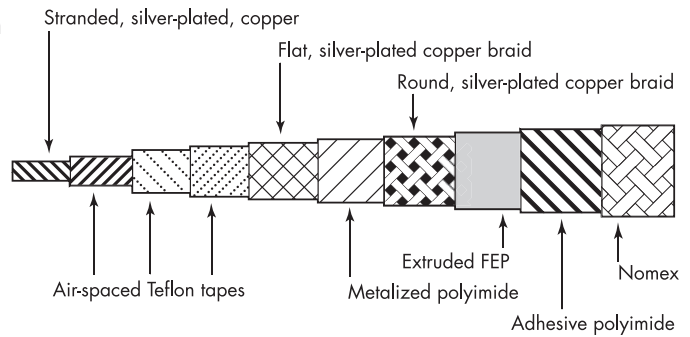

Cable Insertion Loss – Graph 1

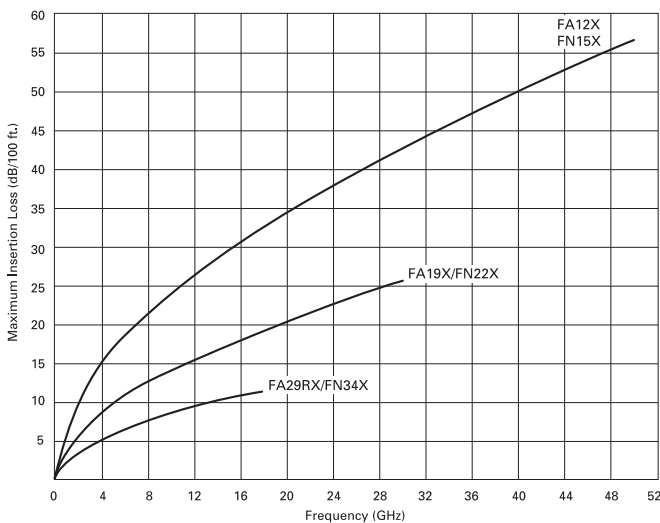

Cable Insertion Loss – Graph 2

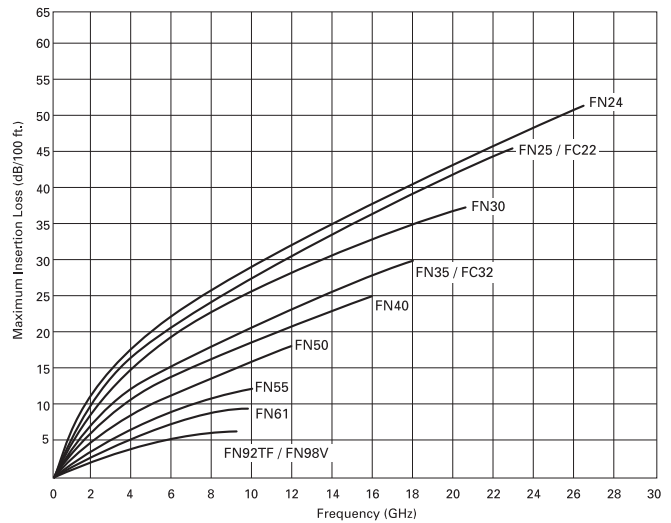

Name	OD (in.)	FCO (GHz)	Fass'y (GHz)	Maximum Insertion Loss: dB/100 ft.										Curve Graph	
				Maximum Power Handling (watts)											
				0.1 GHz	1 GHz	2 GHz	4 GHz	8 GHz	12 GHz	18 GHz	26.5 GHz	40 GHz	50 GHz		
FA09X	0.09	65	18	8.7	26.2	37.2	52.8	75.1	92.5	113.9					
				766.7	254.1	179.3	126.2	88.7	72.1	58.5					
FN11Z	0.14	50	10	6.7	20.4	29.0	41.4	59.4							
				1544.5	508.0	357.3	250.1	174.3							
FA12X	0.12	50	26.5	4.8	14.6	20.7	29.6	42.4	52.4	65.0	80.0			1	
				1852.4	609.8	429.1	300.5	209.7	169.5	136.7	111.1				
FN12TF	0.12	50	50	6.8	20.6	29.3	41.8	60.0	74.3	92.2	113.5	142.2	160.8		
				1310.8	431.2	303.3	212.3	148.0	119.6	96.4	78.3	62.5	55.2		
FA15X	0.15	40	18	3.6	11.1	15.8	22.6	32.5	40.3	50.1				1	
				3059.8	1003.2	704.9	492.2	342.0	275.6	221.5					
FC15EX	0.15	35	18	4.5	14.3	20.7	30.5	45.5	58.1	74.6					
				2465.7	776.5	537.4	364.7	243.9	191.2	148.9					
FN15TF	0.16	40	40	5.4	16.4	23.3	33.4	48.1	59.7	74.4	91.9				
				2202.8	722.1	507.3	354.2	246.1	198.3	159.3	128.9				
FN15X	0.15	50	26.5	4.8	14.6	20.7	29.6	42.4	52.4	65.0	80.0				
				2315.5	762.2	536.4	375.7	262.1	211.8	170.9	138.9				
FC17EX	0.17	30	18	3.8	12.2	17.7	26.2	39.4	50.5	65.1					
				3292.4	1029.9	711.1	480.3	319.5	249.4	193.3					
FN17EX	0.17	35	18	4.5	14.3	20.7	30.5	45.5	58.1	74.6					
				2794.5	880.0	609.1	413.3	276.5	216.7	168.7					
FA19	0.18	26.5	26.5	3.4	10.4	14.9	21.4	31.2	39.0	48.9	61.0				
				3945.6	1280.9	896.6	621.5	427.6	342.0	272.5	218.4				
FA19HFX	0.19	30	18	3.2	9.6	13.7	19.7	28.5	35.4	44.1					
				4457.0	1457.8	1023.3	713.3	494.4	397.6	318.8					
FA19MX	0.19	30	18	3.2	9.6	13.7	19.7	28.5	35.4	44.1					
				4457.0	1457.8	1023.3	713.3	494.4	397.6	318.8					
FA19X	0.19	30	26.5	2.7	8.2	11.8	17.0	24.5	30.6	38.3	47.5			1	
				5217.4	1701.0	1192.6	829.3	573.0	459.8	367.6	295.9				
FN19EX	0.19	30	18	3.8	12.2	17.7	26.2	39.4	50.5	65.1					
				3679.7	1151.0	794.8	536.9	357.0	278.8	216.1					
FN19TF	0.19	26.5	26.5	3.4	10.4	14.9	21.4	31.2	39.0	48.9	61.0				
				4164.8	1352.0	946.4	656.0	451.3	361.0	287.6	230.5				
FA20X	0.20	28	26.5	2.5	7.8	11.1	16.0	23.2	28.9	36.2	45.1				
				5838.5	1900.9	1332.1	925.4	638.5	511.8	408.7	328.5				
FN22	0.22	28	18	3.2	9.8	14.0	20.2	29.4	36.8	46.3				2	
				5136.7	1664.7	1164.5	806.3	553.8	442.4	351.9					
FN22X	0.22	30	26.5	2.7	8.3	11.8	17.0	24.5	30.6	38.3	47.5			1	
				6041.2	1969.6	1380.9	960.9	663.5	532.4	425.7	342.6				
FN22XM	0.22	30	26.5	2.7	8.3	11.8	17.0	24.5	30.6	38.3	47.5				
				4315.1	1406.9	986.4	685.9	473.9	380.3	304.0	244.7				
FN24	0.24	26.5	26.5	2.8	8.5	12.2	17.7	25.9	32.5	41.0	51.4			2	
				6450.2	2081.7	1454.0	1003.6	686.5	546.9	433.6	345.7				
FN25	0.25	23.5	18	2.6	8.1	11.5	16.7	24.5	30.8	38.9				2	
				7132.0	2297.3	1603.3	1105.2	754.6	600.3	475.2					

Name	OD (in.)	FCO (GHz)	Fass'y (GHz)	Maximum Insertion Loss: dB/100 ft.										Curve Graph
				Maximum Power Handling (watts)										
				0.1 GHz	1 GHz	2 GHz	4 GHz	8 GHz	12 GHz	18 GHz	26.5 GHz	40 GHz	50 GHz	
HTS28	0.28	26	18	2.8	8.7	12.5	18.1	26.4	33.1	41.7				
				7369.7	2380.0	1662.7	1148.3	786.0	626.4	496.9				
FA29X	0.30	18	18	1.6	4.9	7.0	10.1	14.5	18.1	22.5				1
				13755.1	4500.8	3160.0	2203.3	1527.8	1229.2	986.0				
FN30	0.30	20	18	2.2	7.0	10.1	14.6	21.6	27.2	35.0				2
				9891.1	3169.4	2207.8	1516.2	1030.1	816.6	643.8				
FN31X	0.31	18.5	18	1.7	5.1	7.4	10.6	15.5	19.4	24.5				
				13788.1	4461.1	3119.0	2156.9	1479.1	1180.3	937.7				
FN34X	0.34	18	18	1.6	4.9	7.0	10.1	14.5	18.1	22.5				1
				15589.1	5100.9	3581.3	2497.0	1731.5	1393.1	1117.4				
FN35	0.35	18	18	2.0	6.2	8.9	13.0	19.2	24.3	31.0				2
				13150.0	4191.1	2913.7	1993.4	1347.7	1064.6	835.9				
FN35WW	0.40	18	18	2.0	6.2	8.9	13.0	19.2	24.3	31.0				
				15028.5	4789.9	3329.9	2278.2	1540.2	1216.6	955.3				
HTS38	0.38	18	18	1.9	5.8	8.4	12.3	18.3	23.2	29.6				
				15140.2	4812.7	3342.5	2282.6	1539.6	1214.0	951.4				
FN40	0.37	16.5	16.5	1.7	5.3	7.6	11.2	16.7	21.2					2
				16407.7	5188.5	3596.6	2447.4	1643.0	1291.4					
FC49	0.50	10	10	1.0	3.4	5.0	7.4	11.4						
				35450.7	10876.5	7458.7	4975.1	3256.8						
FN50V	0.48	12	6	1.5	4.8	6.9	10.3	15.5	19.9					
				23932.2	7448.9	5134.2	3456.6							
FN50	0.50	12	12	1.4	4.3	6.3	9.3	14.0						2
				27294.5	8525.7	5883.8	3970.7	2637.5	2057.8					
HTS53				1.4	4.3	6.3	9.3	14.0	18.0					
				28932.1	9037.2	6236.9	4208.9	2795.8	2181.3					
FN55	0.55	10	10	1.0	3.2	4.7	7.1	10.3						2
				41007.6	12559.0	8607.2	5734.7	3748.8						
FN61	0.61	8	8	1.0	3.1	4.5	9.8							2
				45408.9	14409.1	10001.0	6821.5	4593.6						
FN92TF	0.92	5	5	0.6	2.0	2.9	4.5							2
				115411.5	34121.8	23106.0	15068.0							
FN98V	0.98	5	5	0.6	2.0	2.9	4.5							2
				122938.4	36347.2	24613.0	16050.7							

ilent Technologies E8362B 10 MHz - 20 GHz
PNA Series Network Analyzer

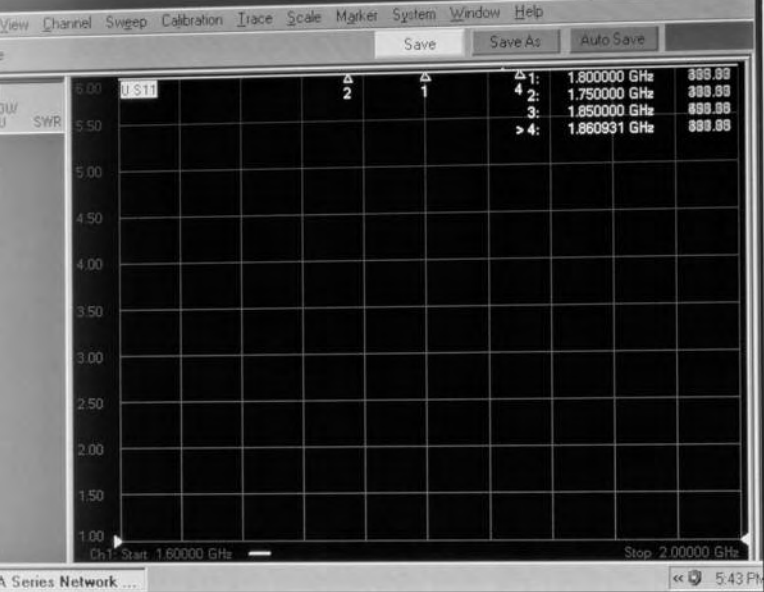

NAVIGATION

↑
Click
↓

Tab ← Tab →

DISPLAY

Trace Window Start / Center
Measure Setups Measure Setup Sweep Setup
Trigger

COMMAND

OK Help
Cancel Menu Dialog

ENTRY

F1 F2 F3 F4

7 8 9 G/n
4 5 6 M/μ
1 2 3 Enter
0 . +/- ←

Probe Power

Save Recall

PORT 1 CALIBRATION PORT 2

IDF 106352 LIC
CAL 11/01/06
DATE 10/28/07

106352
M&COM

TRANS FWD REFL FWD
TRANS REV REFL REV

+30 dBm (1W) RF 40 VDC Max AVOID STATIC DISCHARGE

Agilent
DO NOT
MUST
DURING
E
Config
C



FN25G general test cable



In many applications, increased signal strength may equate to higher system performance. For those situations, we offer these high performance cable assemblies with solid center conductors to provide an even lower loss interconnect than our stranded center conductor cable assemblies.

Just like our high performance EW cable assemblies, the very low loss family meets the requirements of the major military specifications MIL-T-81490 and MIL-C-871 04, which will meet the demanding requirements of your application.

Connectors

A broad selection of popular connector interface styles is available for these cable types. To ensure your cable assembly performs to specifications, these high-quality connectors provide low VSWR and excellent cable/connector retention characteristics.

See pages 56-58 for a selection of typical connector outline dimensions.

Construction details for FN--RL

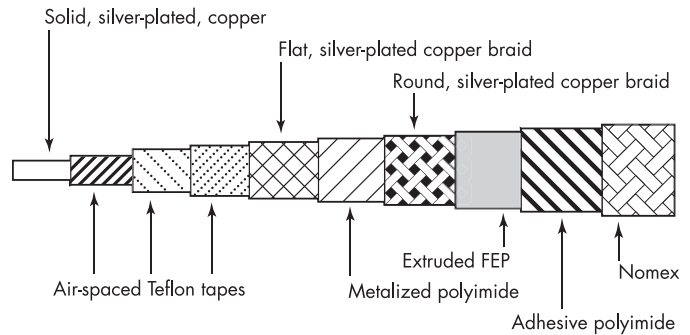

Cable Insertion Loss – Graph 1

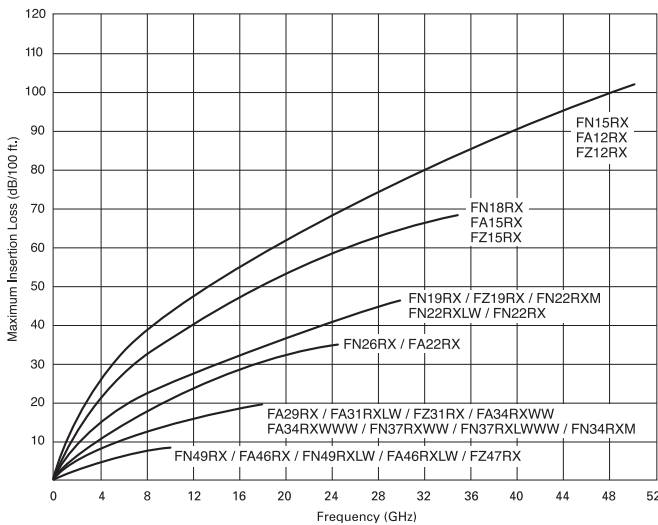

Cable Insertion Loss – Graph 2

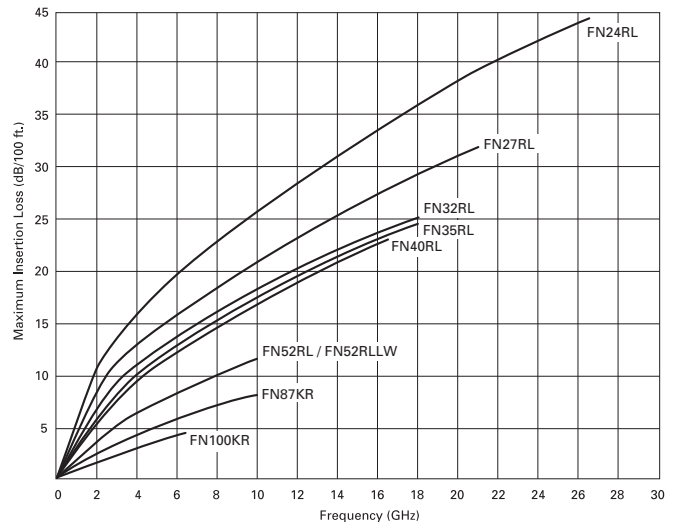

Name	OD (in.)	FCO (GHz)	Fass'y (GHz)	Maximum Insertion Loss: dB/100 ft.											Curve Graph
				Maximum Power Handling (watts)											
				0.1 GHz	1 GHz	2 GHz	4 GHz	8 GHz	12 GHz	18 GHz	26.5 GHz	40 GHz	50 GHz		
FN37	0.37	18	18	2.0	6.3	9.1	13.2	19.6	24.8	31.5					
				13622.6	4345.6	3022.0	2068.8	1399.8	1106.3	869.2					
FA05LX	0.05	130	18	18.0	54.2	76.8	108.8	154.3	189.5	232.7					
				193.1	64.2	45.3	32.0	22.5	18.4	15.0					
FA07LX	0.07	100	18	10.0	30.2	42.8	60.8	86.5	106.3	130.9					
				517.0	171.5	121.0	85.2	59.9	48.7	39.6					
FA09LX	0.09	65	20	7.2	21.8	30.9	44.0	62.7	77.2	100.6					
				922.3	305.3	215.3	151.4	106.3	86.3	70.0					
FA12RX	0.12	50	50	4.3	13.1	18.6	26.6	38.1	47.2	58.6	72.3	90.6	102.5	1	
				2068.0	679.8	478.1	334.5	233.2	188.1	151.5	123.0	98.0	86.7		
FA15RX	0.15	40	40	3.4	10.3	14.6	21.0	30.2	37.5	46.7	57.8	72.9		1	
				3302.4	1081.4	759.4	529.8	367.6	295.6	237.5	192.0	152.4			
FN15RX	0.15	40	18	4.3	13.1	18.6	26.6	38.1	47.2	58.6	72.3			1	
				2585.0	849.7	597.6	418.1	291.3	235.2	189.4	153.7				
FN18RL	0.18	40	18	4.1	12.7	18.0	25.9	37.5	46.8	58.5					
				3228.7	1053.1	738.5	513.7	355.1	285.0	228.0					
FN18RX	0.18	40	40	3.4	10.3	14.6	21.0	30.2	37.5	46.7	57.8	72.9		1	
				3962.9	1297.7	911.3	635.8	441.2	355.1	285.1	230.4	182.9			
FA19RX	0.19	30	26.5	2.4	7.5	10.7	15.4	22.3	27.8	34.9	43.4			1	
				5790.1	1883.3	1319.2	915.7	631.2	505.6	403.4	323.9				
FA20RX	0.20	28	26.5	2.2	6.8	9.7	14.1	20.4	25.6	32.1	40.1				
				6691.6	2171.3	1519.6	1053.1	724.1	579.0	461.1	369.4				
FA22RX	0.22	24	18	2.0	6.3	9.0	13.0	18.9	23.7	29.8				1	
				8025.7	2598.0	1816.6	1256.7	862.2	688.2	547.0					
FA22RXWW	0.22	30	26.5	2.5	7.7	11.0	18.8	22.9	28.6	35.8	44.6				
				6507.9	2118.2	1484.2	1030.8	711.0	569.8	454.9	365.5				
FN22RX	0.22	30	26.5	2.4	7.5	10.7	15.4	22.3	27.8	34.9	43.4			1	
				6704.3	2180.6	1527.5	1060.3	730.8	585.4	467.1	375.1				
FN22RXM	0.22	30	26.5	2.4	7.5	10.7	15.4	22.3	27.8	34.9	43.4			1	
				4788.8	1557.6	1091.1	757.4	522.0	418.1	333.6	267.9				
FN24RL	0.24	26.5	26.5	2.5	7.9	11.3	16.4	24.0	30.2	38.2	48.0			2	
				7002.3	2253.8	1572.5	1083.4	739.2	587.7	464.9	369.8				
FA25RX	0.25	20	18	1.8	5.6	8.0	11.6	16.9	21.2	26.8					
				10304.9	3323.4	2320.6	1601.0	1094.4	871.4	690.4					
FN25RXWW	0.25	30	26.5	2.5	7.7	11.0	18.8	22.9	28.6	35.8	44.6				
				7618.5	2478.0	1735.8	1204.9	830.5	665.2	530.8	426.2				
FN26RX	0.26	24	18	2.0	6.3	9.0	13.0	18.9	23.7	29.8				1	
				9484.9	3070.4	2146.9	1485.2	1018.9	813.4	646.4					
FN27R	0.27	21	18.2	2.0	6.3	9.1	13.3	19.7	24.9	31.7					
				9875.3	3151.1	2191.6	1500.6	1015.6	802.8	630.9					
FA29RX	0.30	18	18	1.4	4.3	6.2	8.9	12.8	16.0	20.0				1	
				15699.6	5123.9	3593.8	2501.0	1729.7	1389.0	1111.6					
FN31RX	0.31	18.5	18	1.4	4.3	6.2	8.9	12.8	16.0	20.0					
				14638.2	4727.9	3303.1	2281.2	1561.6	1244.6	987.3					

Name	OD (in.)	FCO (GHz)	Fass'y (GHz)	Maximum Insertion Loss: dB/100 ft.										Curve Graph	
				Maximum Power Handling (watts)											
				0.1 GHz	1 GHz	2 GHz	4 GHz	8 GHz	12 GHz	18 GHz	26.5 GHz	40 GHz	50 GHz		
FN32RX	0.32	18.5	18.2	1.6	4.9	7.0	10.1	14.7	18.4	23.0					
				14779.7	4805.9	3366.2	2336.2	1609.9	1289.3	1028.5					
FN32RL	0.32	18.2	18.2	1.7	5.4	7.8	11.4	17.0	21.6	27.7				2	
				13847.6	4384.3	3040.6	2070.8	1391.7	1094.7	855.4					
FA34RXWW	0.34	18	18	1.5	4.5	6.4	9.1	13.2	16.4	20.5				1	
				17264.1	5637.9	3955.4	2753.8	1905.8	1531.1	1226.0					
FN34RX	0.34	18	18	1.4	4.3	6.2	8.9	12.8	16.0	20.0				1	
				17792.9	5807.0	4073.0	2834.5	1960.4	1574.2	1259.8					
FN34RXM	0.34	18	18	1.4	4.3	6.2	8.9	12.8	16.0	20.0				1	
				12709.2	4147.9	2909.3	2024.6	1400.3	1124.4	899.9					
FN35RL	0.35	18	18	1.5	4.8	6.9	10.2	15.2	19.4	25.0				2	
				17284.2	5434.0	3758.9	2547.7	1701.7	1332.8	1036.5					
FN37RXWW	0.37	18	18	1.5	4.5	6.4	9.1	13.2	16.4	20.5				1	
				18787.4	6135.4	4304.4	2996.8	2074.0	1666.2	1334.2					
FN40RL	0.37	16.5	16.5	1.5	4.7	6.8	10.0	15.0	19.2					2	
				18531.4	5821.4	4025.7	2727.1	1820.3	1424.9	1169.8					
FA46RX	0.46	11	9	1.0	3.1	4.5	6.5	9.7						1	
				34708.1	11006.3	7637.4	5207.0	3504.3							
FN49RX	0.49	11	9	1.0	3.1	4.5	6.5	9.7						1	
				36971.7	11724.1	8135.5	5546.6	3732.9							
FN52RL	0.52	10.5	10.5	1.0	3.2	4.6	6.8	11.6						2	
				38647.9	12148.3	8402.9	5694.6	3803.0							
FN87KR	0.87	5	5	0.6	1.8	2.6	4.0							2	
				116358.0	35563.6	24355.9	16206.8								
FN100KR	0.99	4	4	0.5	1.6	2.3	3.5							2	
				152838.8	46122.9	31449.2	20761.8								





Cobham offers new lighter weight cable products utilizing the properties of our proven FN34RX cable assemblies. These products are intended for use in high-performance airborne applications, including commercial aircraft.

The FN34RX assembly is a DC to 18 GHz, 0.34" diameter cable, operational at temperatures up to +200° C. This reduced weight FN34RXLW uses a silver-plated, copper-clad aluminum center conductor and silver-plated aluminum shielding. It has a greater than 32 percent weight reduction with no impact on electrical performance.

Connectors

A broad selection of popular connector interface styles is available for these cable types. To ensure your cable assembly performs to specifications, these high-quality connectors provide low VSWR and excellent cable/connector retention characteristics.

See pages 56-58 for a selection of typical connector outline dimensions.

Construction details for FN--RXLW

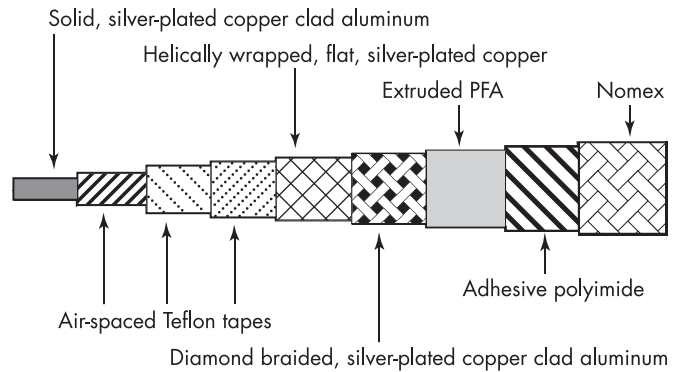

Cable Insertion Loss

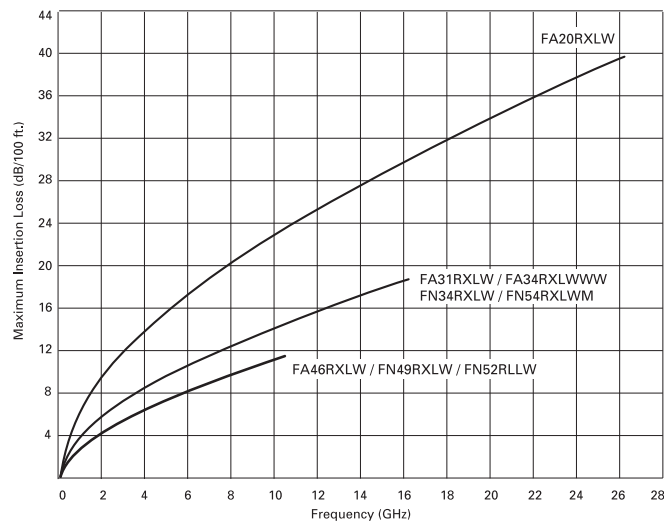

Name	OD (in.)	Wgt (lb/ft)	FCO (GHz)	Fass'y (GHz)	Maximum Insertion Loss: dB/100 ft.									
					Maximum Power Handling (watts)									
					0.1 GHz	1 GHz	2 GHz	4 GHz	8 GHz	12 GHz	18 GHz	26.5 GHz	40 GHz	50 GHz
FA20RXLW	0.20	0.0273	28	26.5	2.2	6.8	9.7	14.1	20.4	25.6	32.1	40.1		
					6691.6	2171.3	1520	1053.1	724.1	579	461.1	369.4		
FA31RXLW	0.31	0.0651	18	18	1.4	4.3	6.2	8.9	12.8	16.0	20.0			
					16222.9	5294.7	3713.5	2584.4	1787.4	1435.3	1148.7			
FA34RXLWWW	0.34	0.0965	18	18	1.5	4.5	6.4	9.1	13.2	16.4	20.5			
					17668.0	5767.1	4045.3	2815.4	1947.5	1564.0	1251.8			
FN34RXLW	0.34	0.0714	18	18	1.4	4.3	6.2	8.9	12.8	16.0	20.0			
					17792.9	5807.0	4073.0	2834.5	1960.4	1574.2	1259.8			
FN34RXLWM	0.34	0.0714	18	18	1.4	4.3	6.2	8.9	12.8	16.0	20.0			
					12709.2	4147.9	2909.3	2024.6	1400.3	1124.4	899.9			
FA46RXLW	0.46	0.1310	11	9	1.0	3.1	4.5	6.5	9.7					
					34708.1	11006.3	7637.4	5207.0	3504.3					
FN49RXLW	0.49	0.1678	11	9	1.0	3.1	4.5	6.5	9.7					
					36971.7	11724.1	8135.5	5546.6	3732.9					
FN52RLLW	0.52	0.1840	10.5	10.5	1.0	3.2	4.6	6.8	11.6					
					38647.9	12148.3	8402.9	5694.6	3803.0					



Coaxial cable runs for most applications require a flexible cable that permits flexing during installation, service, and sometimes the actual operation of the system. Braided electrical shields and PTFE tape-wrapped dielectric make a cable assembly flexible and pliable. These allow repeated flexures without damage. When long, continuous runs of coaxial cable (up to 1800 ft) are needed to connect an antenna and a transmit/receive module, the unique construction of our mast cables permits the cable to be mounted on a reel for re-deployable systems. We also supply cable assembly on the reel with pulling grips and hangers ready to use in your system.

Shipboard versions of this cable, identified by the part number code LSX, are designed for low smoke and halogen free jackets. Both ground-based and shipboard cables also can be supplied with a solid center conductor for lower loss.

Connectors

A broad selection of popular connector interface styles is available for these cable types. To ensure your cable assembly performs to specifications, these high-quality connectors provide low VSWR and excellent cable/connector retention characteristics.

See pages 56-58 for a selection of typical connector outline dimensions.

Construction details for FE—

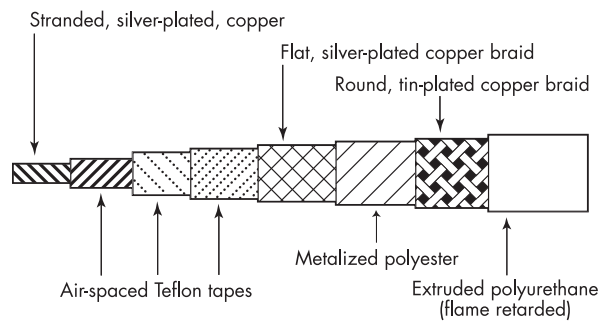

Cable Insertion Loss – Graph 1

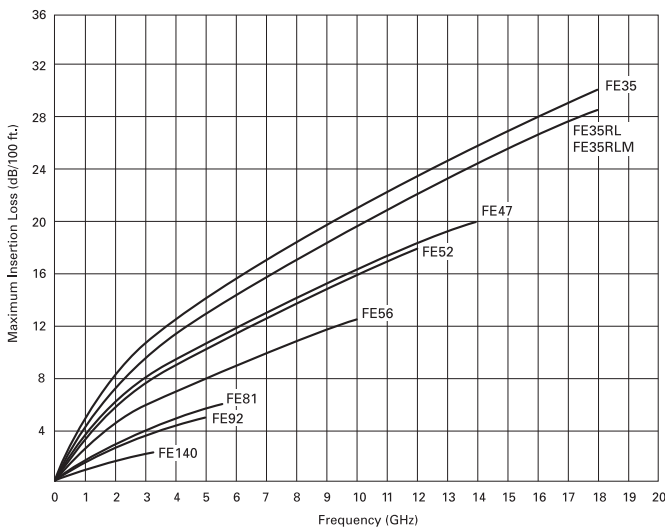

Cable Insertion Loss – Graph 2

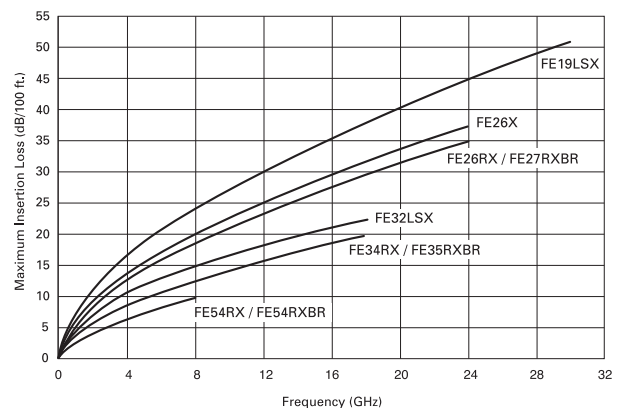

Name	OD (in.)	FCO (GHz)	Fass'y (GHz)	Maximum Insertion Loss: dB/100 ft.									Curve Graph
				Maximum Power Handling (watts)									
				0.1 GHz	1 GHz	2 GHz	4 GHz	8 GHz	12 GHz	18 GHz	26.5 GHz		
FE19LSX	0.19	30	26.5	2.7	8.3	11.8	17.0	24.5	30.6	38.3	47.5	2	
				2236.0	729.0	511.1	355.4	245.6	197.0	157.6	126.8		
FE26RX	0.26	24	18	2.0	6.3	9.0	13.0	18.9	23.7	29.8		2	
				4065.0	1315.9	920.1	636.5	436.7	348.6	277.0			
FE26X	0.26	24	18	2.2	6.8	9.7	14.0	20.4	25.5	32.0		2	
				3745.1	1215.1	850.4	589.2	405.1	323.9	257.9			
FE27RXBR	0.27	24	18	2.0	6.3	9.0	13.0	18.9	23.7	29.8		2	
				4221.3	1366.5	955.5	661.0	453.5	362.0	287.7			
FE32LSX	0.32	18	18	1.6	4.9	7.0	10.1	14.5	18.1	22.5		2	
				6288.0	2057.5	1444.6	1007.2	698.4	561.9	450.7			
FE34RX	0.34	18	18	1.4	4.3	6.2	8.9	12.8	16.0	20.0		2	
				7625.5	2488.7	1745.6	1214.8	840.2	674.7	539.9			
FE35RL	0.35	18	18	1.5	4.8	6.9	10.2	15.2	19.4	25.0		1	
				7407.5	2328.9	1611.0	1091.9	729.3	571.2	444.2			
FE35RLM	0.35	18	18	1.5	4.8	6.9	10.2	15.2	19.4	25.0		1	
				7407.5	2328.9	1611.0	1091.9	729.3	571.2	444.2			
FE35RXBR	0.35	18	18	1.4	4.3	6.2	8.9	12.8	16.0	20.0		2	
				7795.7	2510.0	1751.6	1207.0	823.8	655.2	518.4			
FE35	0.35	18	18	2.0	6.2	8.9	13.0	19.2	24.3	31.0		1	
				5635.7	1796.2	1248.7	854.3	577.6	456.2	358.2			
FE47	0.47	13	13	1.4	4.4	6.4	9.4	14.2	18.2			1	
				10825.8	3386.6	2338.4	1579.6	1050.6	820.4				
FE54RX	0.54	8	8	1.0	3.1	4.5	6.5	9.7				2	
				17461.8	5537.3	3842.4	2619.7	1763.0					
FE55RXBR	0.55	8	8	1.0	3.1	4.5	6.5	9.7				2	
				17785.2	5639.9	3913.6	2668.2	1795.7					
FE56	0.56	10	10	1.0	3.2	4.7	7.1	10.9				1	
				17894.2	5480.3	3755.9	2502.4	1635.9					
FE81	0.81	6	6	0.7	2.3	3.3	5.1					1	
				37748.9	11331.1	7712.1	5074.8						
FE92	0.92	5	5	0.6	2.0	2.9	4.5					1	
				49462.1	14623.7	9902.6	6457.7						
FE140	1.40	3.5	3	0.5	1.6	2.3						1	
				97224.9	29203.0	19880.5							



Many cables in this group feature unique constructions to assure long flexure life under constant scanning conditions. Most of these products are helically shielded designs to provide excellent VSWR, very low loss, improved phase stability versus temperature, lightweight, and low bending force.

These products are ideally suited for interconnecting modules within subsystems or devices within modules in very densely packed locations. Their versatile designs can substantially improve system performance and reliability. Although intended for missile applications, many of these cables are appropriate for high performance military aircraft

Cables are available in both phase matched and insertion loss matched sets. Cobham cables meet or exceed stringent environmental requirements.

Connectors

A broad selection of popular connector interface styles is available for these cable types. To ensure your cable assembly performs to specifications, these high-quality connectors provide low VSWR and excellent cable/connector retention characteristics.

See pages 56-58 for a selection of typical connector outline dimensions.

Construction details for FA—MX

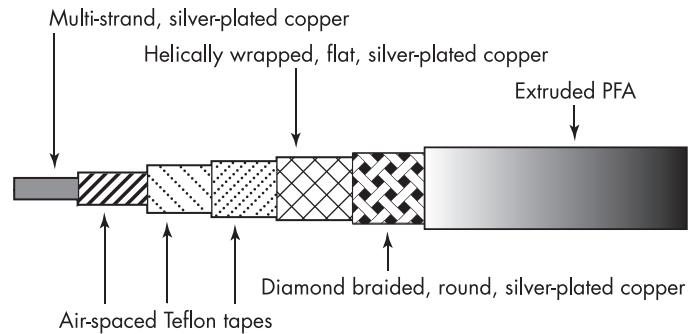

Cable Insertion Loss

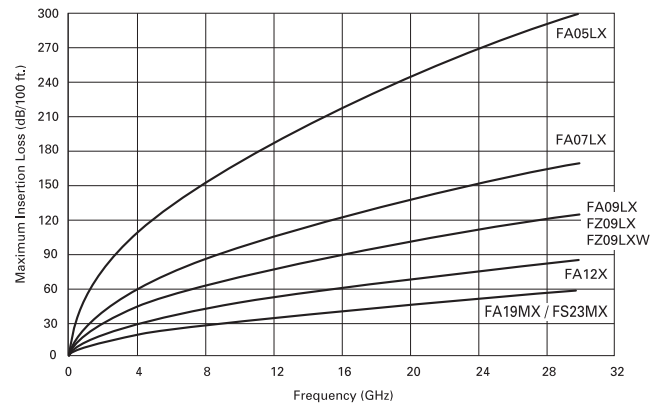

Name	OD (in.)	FCO (GHz)	Fass'y (GHz)	Maximum Insertion Loss: dB/100 ft.							
				Maximum Power Handling (watts)							
				0.1 GHz	1 GHz	2 GHz	4 GHz	8 GHz	12 GHz	18 GHz	26.5 GHz
FA05LX	0.05	130	18	18.0	54.2	76.8	108.8	154.3	189.5	232.7	
				193.1	64.2	45.3	32.0	22.5	18.4	15.0	
FA07LX	0.07	100	18	10.0	30.2	42.8	60.8	86.5	106.3	130.9	
				517.0	171.5	121.0	85.2	59.9	48.7	39.6	
FC07SZ	0.07	50	10	9.7	29.4	41.7	59.4	84.9			
				533.7	176.2	124.2	87.2	61.0			
FT08	0.08	50	3	10.7	32.3	45.8					
				554.7	183.3	129.2					
FA09LX	0.09	65	20	7.2	21.8	30.9	44.0	62.7	77.2	95.2	
				922.3	305.3	215.3	151.4	106.3	86.3	70.0	
FA09HFX	0.09	65	18	8.7	26.2	37.2	52.8	75.1	92.5	113.9	
				766.7	254.1	179.3	126.2	88.7	72.1	58.5	
FA09X	0.09	65	18	8.7	26.2	37.2	52.8	75.1	92.5	113.9	
				766.7	254.1	179.3	126.2	88.7	721.0	58.5	
FG09	0.09	74	18	9.7	29.4	41.7	59.4	84.9	104.8	129.5	
				686.2	226.6	159.7	112.1	78.5	63.6	51.4	
FZ09LX	0.09	65	18	7.2	21.8	30.9	44.0	62.7	77.2	95.2	
				658.8	218.1	153.8	108.2	75.9	61.6	50.0	
FZ09LXW	0.09	65	18	7.2	21.8	30.9	44.0	62.7	77.2	95.2	
				658.8	218.1	153.8	108.2	75.9	61.6	50.0	
FA12RX	0.12	50	26.5	4.3	13.1	18.6	26.6	38.1	47.2	58.6	72.3
				1477.1	485.5	341.5	238.9	166.4	134.4	108.2	87.8
FZ12RX	0.12	50	26.5	4.3	13.1	18.6	26.6	38.1	47.2	58.6	72.3
				1477.1	485.5	341.5	238.9	166.4	134.4	108.2	87.8
FA12X	0.12	50	26.5	4.8	14.6	20.7	29.6	42.4	52.4	65.0	80.0
				1852.4	609.8	429.1	300.5	209.7	169.5	136.7	111.1
FG18	0.18	26.5	18	3.4	10.4	14.9	21.4	31.2	39.0	48.9	
				3945.6	1280.9	896.6	621.5	427.6	342.0	272.5	
FA19HFX	0.19	30	18	3.2	9.6	13.7	19.7	28.5	35.4	44.1	
				4457.0	1457.8	1023.3	713.3	494.4	397.6	318.8	
FA19MX	0.19	30	18	3.2	9.6	13.7	19.7	28.5	35.4	44.1	
				4457.0	1457.8	1023.3	713.3	494.4	397.6	318.8	
FS23MX	0.23	30	18	3.2	9.6	13.7	19.7	28.5	35.4	44.1	
				3853.8	1260.5	884.8	616.7	427.5	343.8	275.7	

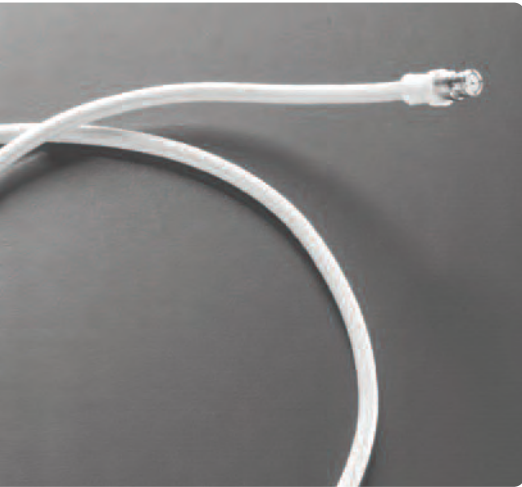

Cables for space applications are helically shielded designs to provide very low loss and improved phase stability versus temperature. Ideally suited for interconnecting modules within subsystems or devices within modules, this versatile design can substantially improve system performance. In addition, helically shielded cables for a given cable size are: light weight, with best phase tracking and lowest bending force. They are available with a Tefzel® radiation resistant jacket (FZ).

Cobham offers a large selection of space cable sizes and connector Interfaces that are available in both phase matched and insertion loss matched sets with unique multipaction-free connectors. Cobham space cables meet or exceed the most stringent requirements.

Connectors

A broad selection of popular connector interface styles is available for these cable types. To ensure your cable assembly performs to specifications, these high-quality connectors provide low VSWR and excellent cable/connector retention characteristics.

See pages 56-58 for a selection of typical connector outline dimensions.

Construction details for FZ--RX

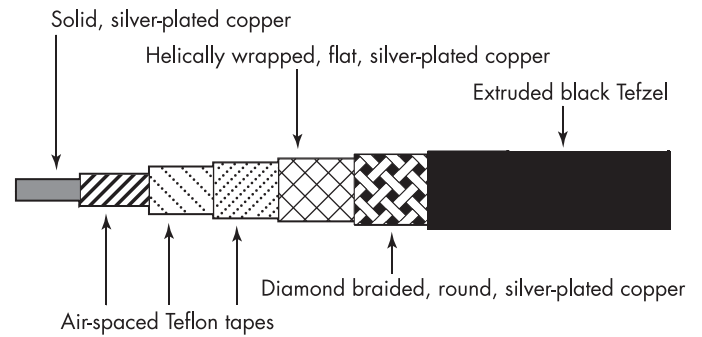

Cable Insertion Loss

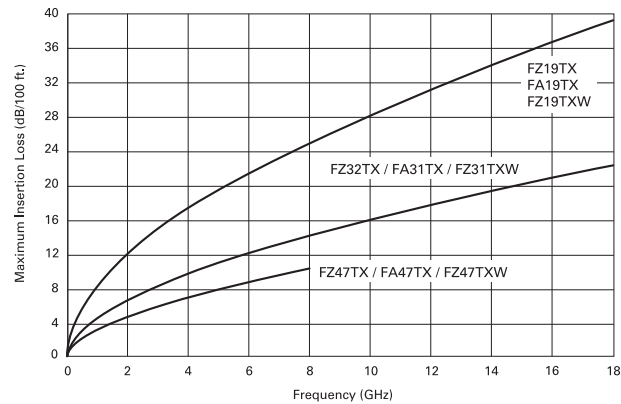

Name	OD (in.)	FCO (GHz)	Fass'y (GHz)	Maximum Insertion Loss: dB/100 ft.									Maximum Power Handling (watts)	
				0.1 GHz	1 GHz	2 GHz	4 GHz	8 GHz	12 GHz	18 GHz	26.5 GHz	40 GHz		
FA05LX	0.05	130	18	18.0	54.2	76.8	108.8	154.3	189.5	232.7				
FA07LX	0.07	100	18	10.0	30.2	42.8	60.8	86.5	106.3	130.9				
FA09LX	0.09	65	20	7.2	21.8	30.9	44.0	62.7	77.2	95.2				
FA09X	0.09	65	18	8.7	26.2	37.2	52.8	75.1	92.5	113.9				
FZ09LX	0.09	65	18	7.2	21.8	30.9	44.0	62.7	77.2	95.2				
FZ09LXW	0.09	65	18	7.2	21.8	30.9	44.0	62.7	77.2	95.2				
FA12RX	0.12	50	50	4.3	13.1	18.6	26.6	38.1	47.2	58.6	72.3	90.6		
FZ12RX	0.12	50	26.5	4.3	13.1	18.6	26.6	38.1	47.2	58.6	72.3			
FA12X	0.12	50	26.5	4.8	14.6	20.7	29.6	42.4	52.4	65.0	80.0			
FA15RX	0.15	40	40	3.4	10.3	14.6	21.0	30.2	37.5	46.7	57.8	72.9		
FA15X	0.15	40	18	3.6	11.1	15.8	22.6	32.5	40.3	50.1				
FN15RX	0.15	40	18	4.3	13.1	18.6	26.6	38.1	47.2	58.6				
FG18	0.18	26.5	18	3.4	10.4	14.9	21.4	31.2	39.0	48.9				
FN18RX	0.18	40	40	3.4	10.3	14.6	21.0	30.2	37.5	46.7	57.8	72.9		
FA19RX	0.19	30	26.5	2.4	7.5	10.7	15.4	22.3	27.8	34.9	43.4			
FZ19RX	0.19	30	26.5	2.4	7.5	10.7	15.4	22.3	27.8	34.9	43.4			
FZ19TX	0.19	30	28	2.8	8.5	12.2	17.5	25.3	31.6	39.4				
FA19RXLW	0.19	30	26.5	2.4	7.5	10.7	15.4	22.3	27.9	34.9	43.4			
FA19TX	0.19	30	26.5	2.8	8.5	12.2	17.5	25.3	31.6	39.4				
FA19X	0.19	30	26.5	2.7	8.3	11.8	17.0	24.5	30.6	38.3	47.5			
FA20RX	0.2	28	26.5	2.2	6.8	9.7	14.1	20.4	25.6	32.1	40.1			
FA20X	0.2	28	26.5	2.5	7.8	11.1	16.0	23.2	28.9	36.2	45.1			

Name	OD (in.)	FCO (GHz)	Fass'y (GHz)	Maximum Insertion Loss: dB/100 ft.								
				Maximum Power Handling (watts)								
				0.1 GHz	1 GHz	2 GHz	4 GHz	8 GHz	12 GHz	18 GHz	26.5 GHz	40 GHz
FN22RX	0.22	30	26.5	2.4	7.5	10.7	15.4	22.3	27.8	34.9	43.4	
FN22TX	0.22	30	18	2.8	8.5	12.2	17.5	25.3	31.6	39.4		
FN22X	0.22	30	26.5	2.7	8.3	11.8	17.0	24.5	30.6	38.3	47.5	
FA25RX	0.25	20	18	1.8	5.6	8.0	11.6	16.9	21.2	26.8		
FA29RX	0.3	18	18	1.4	4.3	6.2	8.9	12.8	16.0	20.0		
FA31TX	0.3	18	18	1.6	4.9	7.0	10.0	14.5	18.0	22.5		
FZ31RX	0.3	18	18	1.4	4.3	6.2	8.9	12.8	16.0	20.0		
FZ31RXW	0.3	18	18	1.4	4.3	6.2	8.9	12.8	16.0	20.0		
FZ31TXW	0.3	18	18	1.6	4.9	7.0	10.0	14.5	18.0	22.5		
FA31RXLW	0.31	18	18	1.4	4.3	6.2	8.9	12.8	16.0	20.0		
FN34RX	0.34	18	18	1.4	4.3	6.2	8.9	12.8	16.0	20.0		
FN34RXLW	0.34	18	18	1.4	4.3	6.2	8.9	12.8	16.0	20.0		
FN34TX	0.34	18	18	1.6	4.9	7.0	10.0	14.5	18.0	22.5		
FA46RX	0.46	8	8	1.0	3.1	4.5	6.5	9.7				
FA46RXLW	0.46	8	8	1.0	3.1	4.5	6.5	9.7				
FZ47RX	0.47	8	8	1.0	3.1	4.5	6.5	9.7				
FZ47RXW	0.47	8	8	1.0	3.1	4.5	6.5	9.7				
FZ47TX	0.47	8	8	1.1	3.4	4.9	7.1	10.5				
FZ47TXW	0.47	8	8	1.1	3.4	4.9	7.1	10.5				
FN49RX	0.49	8	8	1.0	3.1	4.5	6.5	9.7				

Introduction

In the vacuum of space, transmission lines carrying more than 100 watts can be affected by a phenomenon called multipaction, a condition of resonant secondary electrons that can interfere with the primary RF signal.

The conditions necessary for multipaction to exist depend on three variables: (1) the power level, 2) the frequency of the RF signal, and (3) the physical geometry of the transmission line. One can assess the likelihood of multipaction to exist in a structure by consulting a reference work on the subject, such as Final Report on RF Voltage Breakdown in Coaxial Transmission Lines by R. Woo, 1970. Multipaction only exists in volumes of void inside the transmission line that are also in the RF field.

Discussion

In the low-pressure environment of space—or low earth orbit—electrons are free to move without collisions with gases. Transmission lines, such as coaxial cables, are normally vented to bring the internal pressure of the cable to that of the ambient environment. Several different types of high-energy particles from the sun are capable of penetrating cables and connectors, and such particles can produce the free electrons needed for the onset of multipaction.

There are techniques to prevent multipaction. Cobham produces cable assemblies with a power level of 300 watts and a frequency of 1.1 GHz in a “TNC-sized” connector. This special connector has the acronym MTNC (Multipaction-free TNC). Externally an MTNC connector has the same coupling nut size and threads, and the same overall look as a TNC. Internally, an MTNC connector has interlocking cones of dielectric instead of overlapping cylinders, (as in the case of a regular TNC). To prevent multipaction, the cones are precision-dimensioned, making the small conical gap very small, but still allowing for the mechanical movement caused by thermal expansion. Both male and female halves of the connector pair must meet a set of precision interface dimensions, which are carefully defined like all other RF connectors.

Cobham makes connectors and adapters with the MTNC interfaces— adapters to 7 mm, flange-mounted bulkheads, and cable-attached.

Conclusion

Due to the numerical calculation that must be done for each set of conditions, Cobham suggests that for any application requiring power levels approaching 100 watts, you provide your power requirements and our engineering staff will suggest the smallest cable and connector interface that assures you a successful deployment.

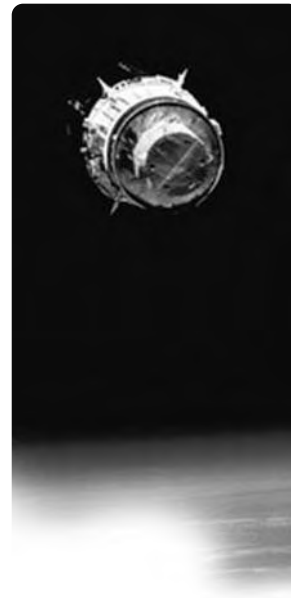



These FEP and/or Nomex-jacketed cables are tougher than other general purpose products for more severe environments. Nomex is a mil-qualified material required on electronic warfare-type cables to protect them from abrasion.

General purpose cable assemblies offer excellent performance: low insertion loss and low VSWR over a broad frequency range. Our proprietary double- and triple-shielded constructions offers high shielding effectiveness without a significant increase in cost or weight. All this in a flexible cable that will provide reliable performance, even after 100,000 flexures.

Connectors

A broad selection of popular connector interface styles is available for these cable types. To ensure your cable assembly performs to specifications, these high-quality connectors provide low VSWR and excellent cable/connector retention characteristics.

See pages 56-58 for a selection of typical connector outline dimensions..

Construction details for FA—RXWW

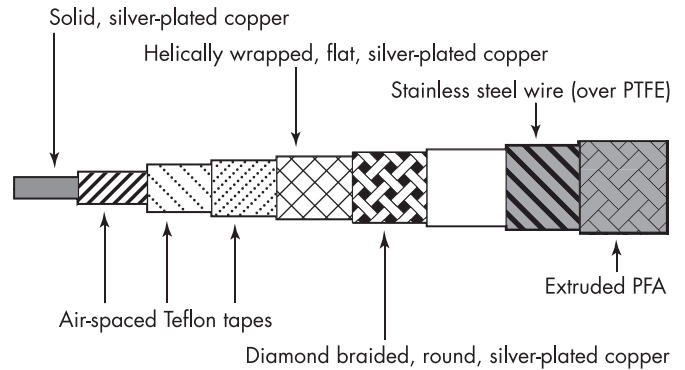

Cable Insertion Loss

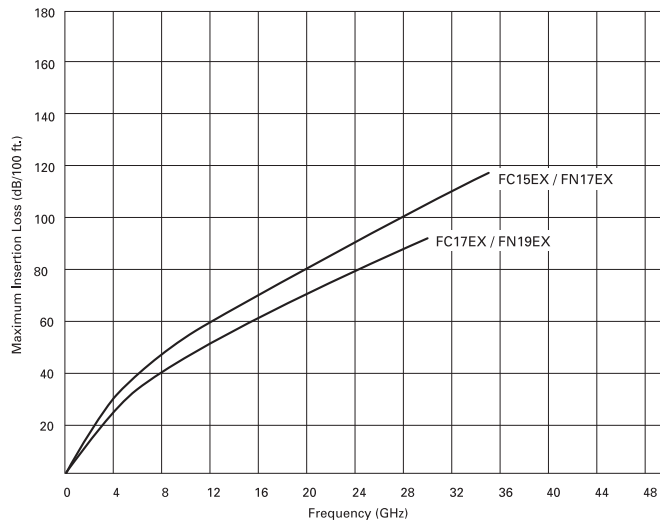

See table on page 42



These assemblies provide the same high quality of workmanship, materials, and performance as our high performance cable assemblies but are designed for less-demanding environments; hence, they cost less.

An added benefit is that one of our durable, flexible cable assemblies can replace the need for hundreds of unique semi-rigid designs, saving design and production time as well as inventory cost.

Connectors

A broad selection of popular connector interface styles is available for these cable types. To ensure your cable assembly performs to specifications, these high-quality connectors provide low VSWR and excellent cable/connector retention characteristics.

See pages 56-58 for a selection of typical connector outline dimensions.

Construction details for FE--ST

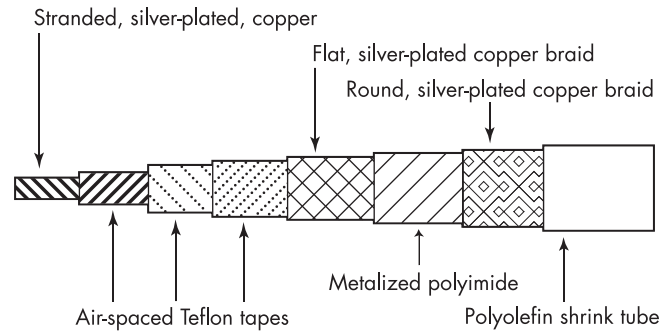

Cable Insertion Loss

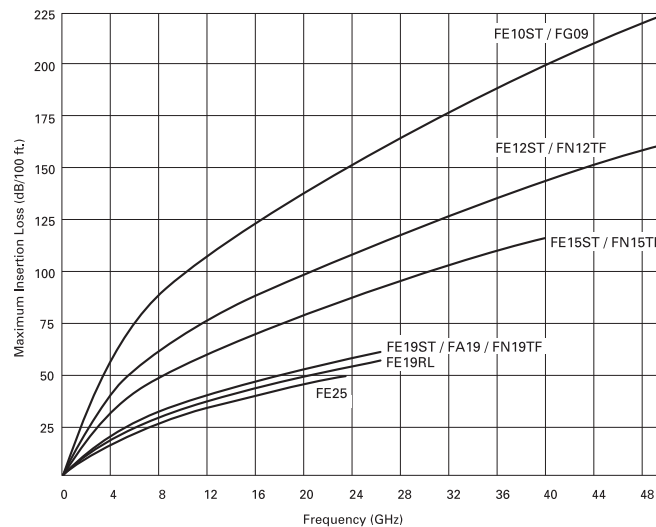

See tables on page 42-43

Name	OD (in.)	FCO (GHz)	Fass'y (GHz)	Maximum Insertion Loss: dB/100 ft.									
				Maximum Power Handling (watts)									
				0.1 GHz	1 GHz	2 GHz	4 GHz	8 GHz	12 GHz	18 GHz	26.5 GHz	40 GHz	50 GHz
Solid Teflon Dielectric													
FC15EX	0.15	35	18	4.5	14.3	20.7	30.5	45.5	58.1	74.6			
				2465.7	776.5	537.4	364.7	243.9	191.2	148.9			
FC17EX	0.17	30	18	3.8	12.2	17.7	26.2	39.4	50.5	65.1			
				3292.4	1029.9	711.1	480.3	319.5	249.4	193.3			
FN17EX	0.17	35	18	4.5	14.3	20.7	30.5	45.5	58.1	74.6			
				2794.5	880.0	609.1	413.3	276.5	216.7	168.7			
FN19EX	0.19	30	18	3.8	12.2	17.7	26.2	39.4	50.5	65.1			
				3679.7	1151.0	794.8	536.9	357.0	278.8	216.1			
Air-Spaced Teflon													
FA05LX	0.05	130	18	18.0	54.2	76.8	108.8	154.3	189.5	232.7			
			193.1	64.2	45.3	32.0	22.5	18.4	15.0				
FA07LX	0.07	100	18	10.0	30.2	42.8	60.8	86.5	106.3	130.9			
			517.0	171.5	121.0	85.2	59.9	48.7	39.6				
FC07SZ	0.07	50	10	9.7	29.4	41.7	59.4	84.9					
			533.7	176.2	124.2	87.2	61.0						
FA09LX	0.09	65	20	7.2	21.8	30.9	44.0	62.7	77.2	95.2			
				922.3	305.3	215.3	151.4	106.3	86.0	70.0			
FA09X	0.09	65	18	8.7	26.2	37.2	52.8	75.1	92.5	113.9			
				766.7	254.1	179.3	126.2	88.7	721.0	58.5			
FE10ST	0.10	74	18	9.7	29.4	41.7	59.4	84.9	104.8	129.5			
				326.8	107.9	76.0	53.4	37.4	30.3	24.5			
FA12RX	0.12	50	50	4.3	13.1	18.6	26.6	38.1	47.2	58.6	72.3	90.6	102.5
			2068.0	679.8	478.1	334.5	233.2	188.1	151.5	123.0	98.0	86.7	
FA12X	0.12	50	26.5	4.8	14.6	20.7	29.6	42.4	52.4	65.0	80.0		
				1852.4	609.8	429.1	300.5	209.7	169.5	136.7	111.1		
FE12RL	0.12	50	50	6.2	18.9	26.9	38.5	55.2	68.4	84.9	104.7	131.2	148.5
				612.2	201.2	141.5	99.0	69.0	55.7	44.8	36.4	29.0	25.6
FE12ST	0.12	50	50	6.8	20.6	29.3	41.8	60.0	74.3	92.2	113.7	142.2	160.8
				561.8	184.8	130.0	91.0	63.4	51.2	41.3	33.5	26.8	23.7
FN12TF	0.12	50	50	6.8	20.6	29.3	41.8	60.0	74.3	92.2	113.7	142.2	160.8
				1310.8	431.2	303.3	212.3	148.0	119.6	96.4	78.3	62.5	55.2
FA15RX	0.15	40	40	3.4	10.3	14.6	21.0	30.2	37.5	46.7	57.8	72.9	
				3302.4	1081.4	759.4	529.8	367.6	296.0	237.5	192.0	152.4	
FA15X	0.15	40	18	3.6	11.1	15.8	22.6	32.5	40.3	50.1			
				3059.8	1003.2	704.9	492.2	342.0	275.6	221.5			
FE15ST	0.15	40	40	5.4	16.4	23.3	33.4	48.1	59.7	74.4	91.8	115.6	
				885.1	290.1	203.8	142.3	99.0	79.7	64.0	51.8	41.2	
FA19	0.18	26.5	26.5	3.4	10.4	14.9	21.4	31.2	39.0	48.9	61.0		
				3945.6	1280.9	896.6	621.5	427.6	342.0	272.5	218.4		
FA19HFX	0.19	30	18	3.2	9.6	13.7	19.7	28.5	35.4	44.1			
				4457.0	1457.8	1023.3	713.3	494.4	397.6	318.8			
FA19MX	0.19	30	18	3.2	9.6	13.7	19.7	28.5	35.4	44.1			
				4457.0	1457.8	1023.3	713.3	494.4	397.6	318.8			
FA19RX	0.19	30	26.5	2.4	7.5	10.7	15.4	22.3	27.8	34.9	43.4		
				5790.1	1883.3	1319.2	915.7	631.2	505.6	403.4	323.9		
FA19RXLW	0.19	30	26.5	2.4	7.5	10.7	15.4	22.3	27.8	34.9	43.4		
				5790.1	1883.3	1319.2	915.7	631.2	505.6	403.4	323.9		
FA19TX	0.19	30	26.5	2.8	8.5	12.2	17.5	25.3	31.6	39.4			
				5042.8	1645.3	1153.9	802.8	555.1	445.6	356.6			

Maximum Insertion Loss: dB/100 ft.

Maximum Power Handling (watts)

Name	OD (in.)	FCO (GHz)	Fass'y (GHz)	0.1 GHz	1 GHz	2 GHz	4 GHz	8 GHz	12 GHz	18 GHz	26.5 GHz	40 GHz	50 GHz
Air-Spaced Teflon (continued)													
FA19X	0.19	30	26.5	2.7	8.3	11.8	17.0	24.5	30.6	38.3	47.5		
				5217.4	1701.0	1192.6	829.3	573.0	459.8	367.6	295.9		
FE19	0.19	26.5	26.5	3.4	10.4	14.9	21.4	31.2	39.0	48.9	60.9		
				1784.9	579.4	405.6	281.2	193.4	154.7	123.3	98.8		
FE19RL	0.19	26.5	26.5	3.0	9.3	13.3	19.3	28.1	35.3	44.4	55.5		
				1995.7	645.9	451.6	312.3	214.2	171.0	135.9	108.6		
FE19ST	0.19	26.5	26.5	3.4	10.4	14.9	21.4	31.2	39.0	48.9	60.9		
				1784.9	579.4	405.6	281.2	193.4	154.7	123.3	98.8		
FA20RX	0.20	28	26.5	2.2	6.8	9.7	14.1	20.4	25.6	32.1	40.1		
				6691.6	2171.3	1519.6	1053.1	724.1	579.0	461.1	369.4		
FA20X	0.20	28	26.5	2.5	7.8	11.1	16.0	23.2	28.9	36.2	45.1		
				5838.5	1900.9	1332.1	925.4	638.5	511.8	408.7	328.5		
FC20	0.19	28	18	3.2	9.8	14.0	20.2	29.4	36.8	46.3			
				4436.3	1437.7	1005.7	696.3	478.2	382.1	304.0			
FN20Z	0.21	28	10	3.2	9.8	14.0	20.2	29.4					
				4903.2	1589.1	1111.6	769.6	528.6					
FC21RL	0.21	26.5	18	2.3	7.3	10.5	15.2	22.4	28.2	35.8			
				6632.3	2128.7	1483.7	1020.1	694.1	550.8	434.8			
FA22RX	0.22	24	18	2.0	6.3	9.0	13.0	18.9	23.7	29.8			
				8025.7	2598.0	1816.6	1256.7	862.2	688.2	547.0			
FA22RXWW	0.22	30	26.5	2.5	7.7	11.0	15.8	22.9	28.6	35.8	44.6		
				6507.9	2118.2	1484.2	1030.8	711.0	569.8	454.9	365.5		
FC22	0.22	23.5	18	2.6	8.1	11.5	16.7	24.5	30.8	38.9			
				6276.1	2021.6	1410.9	972.6	664.1	528.3	418.2			
FA25RX	0.25	20	18	1.8	5.6	8.0	11.6	16.9	21.2	26.8			
				10304.9	3323.4	2320.6	1601.0	1084.4	871.4	690.4			
FE25	0.25	23	18	2.8	8.8	12.6	18.2	26.6	33.4	42.1			
				2789.0	901.0	629.5	434.9	297.8	237.3	188.3			
FN25RXWW	0.25	30	26.5	2.5	7.7	11.0	15.8	22.9	28.6	35.8	44.6		
				7618.5	2478.0	1735.8	1204.9	830.5	665.2	530.8	426.2		
FA29RX	0.30	18	18	1.4	4.3	6.2	8.9	12.8	16.0	20.0			
				15699.6	5123.9	3593.8	2501.0	1729.7	1389.0	1111.6			
FA29X	0.30	18	18	1.6	4.9	7.0	10.1	14.5	18.1	22.5			
				13755.1	4500.8	3160.0	2203.3	1527.8	1229.2	986.0			
FA31RXLW	0.31	18	18	1.4	4.3	6.2	8.9	12.8	16.0	20.0			
				16222.9	5294.7	3713.6	2584.4	1787.4	1435.3	1148.7			
FC32	0.31	18	18	2.0	6.2	8.9	13.0	19.2	24.3	31.0			
				11647.1	3712.1	2580.7	1765.6	1193.7	942.9	740.3			
FA34RXLWWW	0.34	18	18	1.5	4.5	6.4	9.1	13.2	16.4	20.5			
				17668.0	5767.1	4045.3	2815.4	1947.5	1564.0	1251.8			
FA34RXWW	0.34	18	18	1.5	4.5	6.4	9.1	13.2	16.4	20.5			
				17264.1	5637.9	3955.4	2753.8	1905.8	1531.1	1226.0			
FN34X	0.34	18	18	1.6	4.9	7.0	10.1	14.5	18.1	22.5			
				15589.1	5100.9	3581.3	2497.0	1731.5	1391.1	1117.4			
FA46RX	0.46	8	8	1.0	3.1	4.5	6.5	9.7					
				34708.1	11006.3	7637.4	5207.0	3504.3					
FA46RXLW	0.46	8	8	1.0	3.1	4.5	6.5	9.7					
				34708.1	11006.3	7637.4	5207.0	3504.3					
FC49	0.50	10	10	1.0	3.4	5.0	7.4	11.4					
				35450.7	10876.5	7458.7	4975.1	3256.8					



Connectors

A broad selection of popular connector interface styles is available for these cable types. To ensure your cable assembly performs to specifications, these high-quality connectors provide low VSWR and excellent cable/connector retention characteristics.

See pages 56-58 for a selection of typical connector outline dimensions.

An article describing the advantages of flexible over semi-rigid cable assemblies is available upon request.

18 to 26.5 GHz

These durable test cables have the flexibility and reliability required for testing applications, as well as excellent electrical characteristics. Customer-replaceable interfaces allow a single cable to interconnect a variety of male and female interfaces without degrading the low loss and VSWR of the cable assembly.

The outermost layer of these cables may be extruded FEP (for FC type cables) or extruded polyurethane (FE type). For more severe environments, we cover the extruded FEP layer with overlapping layers of adhesive-backed polyimide tape (used as a vapor barrier) and then weave Nomex (saturated in polyimide to prevent fraying). The FN—G-type cable jacketed with green-tinted Nomex will survive very severe abrasive conditions—similar to those required by MIL-T-81490. An alternative way to ruggedize these popular cables is to cover the FEP layer with stainless steel armor. Armored FN—GA-type cables provide even greater crush and abrasion resistance.

26.5 GHz

These automatic network analyzer phase stable instrument test cables give you the stability you need in all three critical areas: phase, amplitude, and VSWR. A significant advance over standard test cable, this new, dependable test cable maintains stability in all three parameters at frequencies up to 26.5 GHz even after 150,000 flexures. Interchangeable connector heads allow a single cable to use interchangeably male and female heads of a given interface without degradation in phase amplitude or VSWR; in other words, a 3.5-mm male head has the same electrical length as the 3.5-mm female head. This feature is important as it allows the change from male to female heads without disturbing a previously performed VNA calibration. Instrument test cables are stocked in various lengths for quick delivery. Please consult the factory for information on custom lengths. There are two types of 26.5 GHz phase stable cables for your ANA needs. They differ in size (OD) and flexibility (ease of use). Don't shortchange yourself on this vital link with your precision automatic network analyzer.

to 50 GHz

This ultra-flexible, phase stable cable assembly provides the necessary phase, amplitude, and VSWR stability you need to perform precision automatic network analyzer tests to 50 GHz with complete confidence. A by-product of our extensive EW experience, this remarkable cable met specifications after being flexed the equivalent of several years of normal laboratory use!

These cable assemblies are packed in a special wooden storage case that prevents harm to its contents when not in use or during transportation.

Maximum Insertion Loss: dB/100 ft.
Maximum Power Handling (watts) as Test Cable

Name	OD (in.)	FCO (GHz)	Fass'y (GHz)	0.1 GHz	1 GHz	2 GHz	4 GHz	8 GHz	12 GHz	18 GHz	26.5 GHz	40 GHz	50 GHz	Cable Type
FE12RL	0.12	50	50	6.2	18.9	26.9	38.5	55.2	68.4	84.9	104.7	131.2	148.5	PS
				5	5	5	5	5	5	5	3	3	3	
FE19	0.19	26.5	26.5	3.4	10.4	14.9	21.4	31.2	39.0	48.9				G
				10	10	10	10	10	10	10				
FE19RL	0.19	26.5	26.5	3.0	9.3	13.3	19.3	28.1	35.3	44.4				G, PS
1010				10	10	10	10	10	10	10				
ITC23	0.23	30	26.5	3.8	12.2	17.7	26.2	39.4	50.5	65.1				PS
FN24G	0.24	26.5	26.5	2.8	8.5	12.2	17.7	25.9	32.5	41.0	51.4			G
				10	10	10	10	10	10	10	10			
FE25	0.25	23	18	2.8	8.8	12.6	18.2	26.6	33.4	42.1				PS
				10	10	10	10	10	10	10				
FN25G	0.25	23.5	18	2.6	8.1	11.5	16.7	24.5	30.8	38.9				G
				10	10	10	10	10	10	10				
FC32	0.31	18	18	2.0	6.2	8.9	13.0	19.2	24.3	31.0				G
				10	10	10	10	10	10	10				
FN35G	0.35	18	18	2.0	6.2	8.9	13.0	19.2	24.3	31.0				G
				10	10	10	10	10	10	10				

* See pages 65-66 for ordering information.

Legend G=General PS=Phase Stable

Construction details for FN--G

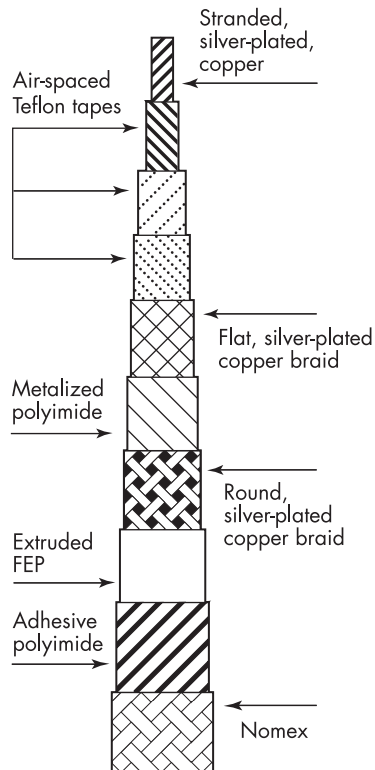

Cable Insertion Loss

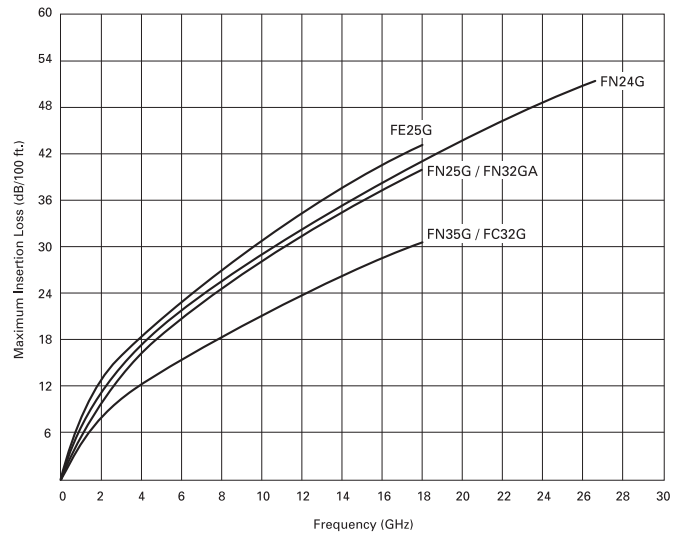



Connectors

A broad selection of popular connector interface styles is available for these cable types. To ensure your cable assembly performs to specifications, these high-quality connectors provide low VSWR and excellent cable/connector retention characteristics.

See pages 56-58 for a selection of typical connector outline dimensions.

Bulk OEM Cable

Cobham lightweight OEM cable can reduce the weight of an aircraft by up to 200 pounds per plane. MIL-DTL-17 RG cables currently used in most aircraft often have twice the outside diameter and three times the weight of Cobham FC—Z lightweight cable, which is typically 50% and as much as 67% lighter. This cable, while smaller and lighter, also performs better, with less insertion loss and higher reliability than RG cable.

Cobham cable also reduces installation labor costs. Its smaller size makes it more flexible and easier to work with so it takes less time to install. Yet it's rugged, as easy to terminate, and more reliable than heavy RG cable.

Cobham cable is certified by the FAA to the requirements of FAR Part 25.1359 (d) Appendix F for flammability. It meets mil specs of the US as well as other governments and NATO.

High Performance Lightweight Cable Assemblies

Cobham offers new lightweight cable assemblies utilizing the FA31RXLW cable, a lightweight version of our proven FA29RX cable assemblies. These products are intended for use in commercial airborne applications. The FA29RX assembly is a DC to 18 GHz, 0.31" diameter cable, operational at temperatures up to +200°C. The reduced weight version, FA31RXLW, using a silver-plated copper-clad aluminum center conductor and a silver-plated aluminum shielding, exhibits a greater than 32 percent weight reduction with no impact on performance.

Cable Insertion Loss

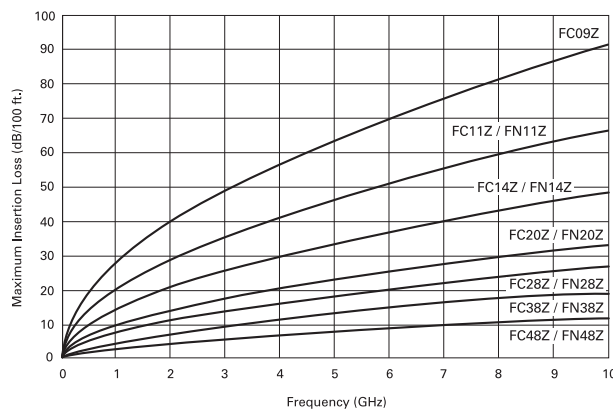

Name	OD (in.)	FCO (GHz)	Fass'y (GHz)	Maximum Insertion Loss: dB/100 ft.						Maximum Power Handling (watts)					
				0.1 GHz	1 GHz	2 GHz	4 GHz	8 GHz	12 GHz	18 GHz					
FC07SZ	0.07	50	10	9.7	29.4	41.7	59.4	84.9	533.7	176.2	124.2	87.2	61.0		
FC09Z	0.09	50	10	9.3	28.2	40.0	57.0	81.5	715.6	236.2	166.4	116.8	81.7		
FC11Z	0.11	50	10	6.7	20.4	29.0	41.4	59.4	1213.5	399.1	280.8	196.5	137.0		
FN11Z	0.14	50	10	6.7	20.4	29.0	41.4	59.4	1544.5	508.0	357.3	250.1	174.3		
FC14Z	0.14	40	10	4.8	14.6	20.8	29.8	43.0	2169.5	709.7	498.2	347.3	240.8		
FN14Z	0.17	40	10	4.8	14.6	20.8	29.8	43.0	2634.4	861.8	605.0	421.8	292.4		
FC20RZ	0.19	28	10	3.1	9.7	13.9	20.0	29.2	4473.9	1449.6	1013.9	701.9	482.0		
FC20Z	0.19	28	10	3.2	9.8	14.0	20.2	29.4	4436.6	1437.7	1005.7	696.3	478.2		
FN20Z	0.21	28	10	3.2	9.8	14.0	20.2	29.4	4903.2	1589.1	1111.6	769.6	528.6		
FC28Z	0.25	21	10	2.5	7.7	11.1	16.1	23.6	7466.1	2400.4	1674.2	1152.5	785.5		
FN28Z	0.28	21	10	2.5	7.7	11.1	16.1	23.6	8362.0	2688.5	1875.1	1290.8	879.8		
FN31RXLW	0.31		18	1.4	4.3	6.2	8.9	12.8	16222.9	5294.7	3713.5	2584.4	1787.4	1435.3	1148.7
FC38RZ	0.32	16	10	1.5	4.7	6.8	10.0	15.0	16027.2	5034.7	3481.7	2358.6	1574.3		
FC38Z	0.32	16	10	1.7	5.3	7.6	11.2	16.7	14190.4	4487.3	3110.6	2116.6	1421.0		
FN38Z	0.34	18	10	1.7	5.3	7.6	11.2	16.7	15520.8	4908.0	3402.2	2315.1	1554.2		
FC48Z	0.49	10	10	1.0	3.4	5.0	7.4	11.4	34741.7	10658.9	7309.5	4875.6	3191.7		
FN48Z	0.52	10	10	1.0	3.4	5.0	7.4	11.4	36868.7	11311.5	7757.0	5174.1	3387.1		

We provide adapters for test labs and for system use. These durable, precision coaxial test adapters provide superior electrical performance and reliable service as test interfaces. Used as “connector-savers,” they also can protect panel connectors from wear. Constructed of gold-plated beryllium copper and stainless steel, these 50-ohm adapters operate from DC to 18 GHz. Interfaces conform to MIL-PRF-39012 and MIL-STD-348.

We also have developed and tested an extensive array of between-series system coaxial adapters for both test and high-power systems applications. Most commonly used connector types are available, all designed to mil-standard interfaces. Many of the system adapters will meet the stringent requirements of MIL-T-81490.

Some of the more common test adapters are summarized below. Contact us for part numbers of TR, SC, and other less common interfaces.

Adapter Type	Part Number	VSWR up to 18 GHz		Nominal OD		Nominal Length	
		Max	Typ	(in.)	(mm)	(in.)	(mm)
Precision 7 mm							
7 mm - Nm	1601-0402	1.08	1.06	0.86	22	2.1	53
7 mm - Nf	1601-0409	1.08	1.06	0.86	22	2.5	64
7 mm - ETNCm	1601-0401	1.10	1.07	0.86	22	2.1	53
7 mm - ETNCf	1601-0408	1.10	1.07	0.86	22	2.5	64
7 mm - SMAm	1601-0403	1.10	1.08	0.86	22	2.0	51
7 mm - SMAf	1601-0407	1.10	1.08	0.86	22	2.0	51
7 mm - 3.5 mm m	1601-0410	1.10	1.06	0.86	22	2.1	53
7 mm - 3.5 mm f	1601-0411	1.10	1.06	0.86	22	2.0	51
7 mm - 7 mm	1601-0404	1.07	1.05	0.86	22	2.2	56
Precision N							
Nm - ETNCm	1601-0201	1.11	1.08	0.79	20	1.9	48
Nm - ETNCf	1601-0208	1.11	1.08	0.79	20	2.4	61
Nm - SMAm	1601-0203	1.11	1.08	0.79	20	1.9	48
Nm - SMAf	1601-0207	1.11	1.08	0.79	20	1.8	46
Nm - 3.5 mm m	1601-0210	1.11	1.08	0.79	20	1.9	48
Nm - 3.5 mm f	1601-0211	1.11	1.08	0.79	20	1.9	48
Nf - ETNCm	1601-0901	1.11	1.09	0.79	20	2.4	61
Nf - ETNCf	1601-0908	1.11	1.09	0.79	20	2.8	71
Nf - SMAm	1601-0903	1.11	1.08	0.79	20	2.3	58
Nf - SMAf	1601-0907	1.11	1.08	0.79	20	2.3	58
Nf - 3.5 mm m	1601-0910	1.11	1.08	0.79	20	2.4	61
Nf - 3.5 mm f	1601-0911	1.11	1.08	0.79	20	2.3	58
Nm - Nf	1601-0209	1.09	1.06	0.79	20	2.4	61
Nm - Nm	1601-0202	1.09	1.06	0.79	20	1.9	48
Nf - Nf	1601-0909	1.09	1.06	0.79	20	2.8	71
Precision ETNC							
ETNCm - Nm	1601-0201	1.11	1.08	0.79	20	1.9	48
ETNCm - Nf	1601-0901	1.11	1.08	0.63	16	2.4	61
ETNCm - SMAm	1601-0103	1.13	1.10	0.63	16	1.9	48
ETNCm - SMAf	1601-0107	1.13	1.10	0.63	16	1.8	46
ETNCm - 3.5 mm m	1601-0110	1.13	1.09	0.63	16	1.9	48

Adapter Type	Part Number	VSWR up to 18 GHz		Nominal OD		Nominal Length		
		Max	Typ	(in.)	(mm)	(in.)	(mm)	
Precision ETNC (con't)								
ETNCm -3.5 mm f	1601-0111	1.13	1.09	0.63	16	1.9	48	
ETNCf - Nm	1601-0208	1.11	1.09	0.63	16	2.4	61	
ETNCf - Nf	1601-0908	1.11	1.09	0.63	16	2.8	71	
ETNCf - SMAm	1601-0803	1.13	1.10	0.63	16	2.4	61	
ETNCf - SMAf	1601-0807	1.13	1.10	0.63	16	2.3	58	
ETNCf - 3.5 mm m	1601-0810	1.13	1.09	0.63	16	2.4	61	
ETNCf - 3.5 mm f	1601-0811	1.13	1.09	0.63	16	2.4	61	
ETNCm - ETNCf	1601-0108	1.13	1.10	0.63	16	2.4	61	
ETNCm - ETNCm	1601-0101	1.13	1.10	0.63	16	1.9	48	
ETNCf - ETNCf	1601-0808	1.13	1.10	0.63	16	2.9	74	
Precision 3.5 mm								
3.5 mm m - Nm	1601-0210	1.11	1.08	0.79	20	1.9	48	
3.5 mm m - Nf	1601-0910	1.11	1.08	0.63	16	2.4	61	
3.5 mm m - ETNCm	1601-0110	1.13	1.09	0.63	16	1.9	48	
3.5 mm m - TNCf	1601-0810	1.13	1.09	0.63	16	2.4	61	
3.5 mm m - SMAm	1601-1003	1.13	1.11	0.63	16	1.9	61	
3.5 mm m - SMAf	1601-1007	1.13	1.11	0.63	16	1.8	46	
3.5 mm f - Nm	1601-0211	1.11	1.08	0.63	16	1.9	48	
3.5 mm f - Nf	1601-0911	1.11	1.08	0.63	16	2.3	58	
3.5 mm f - ETNCm	1601-0111	1.13	1.09	0.63	16	1.9	48	
3.5 mm f-TNCf	1601-0811	1.13	1.09	0.63	16	2.4	61	
3.5 mm f - SMAm	1601-1103	1.13	1.11	0.63	16	1.8	46	
3.5 mm f - SMAf	1601-1107	1.13	1.11	0.63	16	1.8	46	
3.5 mm m - 3.5 mm f	1601-1011	1.13	1.07	0.63	16	1.9	48	
3.5 mm m - 3.5 mm m	1601-1010	1.13	1.07	0.63	16	1.9	48	
3.5 mm f - 3.5 mm f	1601-1111	1.13	1.07	0.63	16	1.8	46	
SMA								
SMAm - ETNCm	1601-0103	1.13	1.10	0.63	16	1.9	48	
SMAm - ETNCf	1601-0803	1.13	1.10	0.63	16	2.4	61	
SMAm - Nm	1601-0203	1.11	1.08	0.79	20	1.9	48	
SMAm - Nf	1601-0903	1.11	1.08	0.63	16	2.3	58	
SMAm - 3.5 mm m	1601-1003	1.13	1.10	0.63	16	1.9	48	
SMAm - 3.5 mm f	1601-1103	1.13	1.10	0.63	16	1.8	46	
SMAf - ETNCm	1601-0107	1.13	1.10	0.63	16	1.8	46	
SMAf - ETNCf	1601-0807	1.13	1.10	0.63	16	2.3	58	
SMAf - Nm	1601-0207	1.11	1.08	0.79	20	1.8	46	
SMAf - Nf	1601-0907	1.11	1.08	0.63	16	2.3	58	
SMAf - 3.5 mm m	1601-1007	1.13	1.10	0.63	16	1.8	46	
SMAf - 3.5 mm f	1601-1107	1.13	1.10	0.63	16	1.8	46	
SMAm - SMAf	1601-0307	1.13	1.11	0.63	16	1.8	46	
SMAm - SMAm	1601-0303	1.13	1.11	0.63	16	1.8	46	
SMAf - SMAf	1601-0707	1.13	1.11	0.63	16	1.7	43	

Rotary adapters are offered in a variety of interfaces. Please request the rotary adapter data sheet.



In addition to the large number of standard cables, connectors, and adapters described elsewhere in this catalog, Cobham also manufactures coaxial products for a broad range of unique applications. To date, we have designed over 500 cables and 5000 connectors to meet specific customer needs. We will design and manufacture coaxial cables, connectors, and adapters to meet any specialized requirements.

**High Technology Shielding
EMI Hardened, EMP Shielded Cable Assemblies**

Lightweight, low loss EMI (Electromagnetic Interference) hardened HTST (High Technology Shielding) coaxial cables are high-performance EW-grade assemblies with EMI shielding protection above 30 MHz that is 50dB better than the best EW cables. Measurements on cable assemblies show that this degree of shielding is possible without degrading other performance parameters. In addition, EMP (Electromagnetic Pulse) shielding is significantly better than is provided by other EW cables. Shielding improvement at 1 GHz is 90 dB better than single-braided RG cables and 60 dB better than double braided. And yet, a substantial reduction in weight is achieved compared to an equivalent shielding performance utilizing additional metallic shielding layers.

These cable assemblies will meet or exceed the applicable EW cable mil specs. These special cable assemblies are in use or many systems in which RF shielding is important without degradation to insertion loss or flexibility. The significant HF shielding elements of HTS shielding may be applied to any high performance cable.

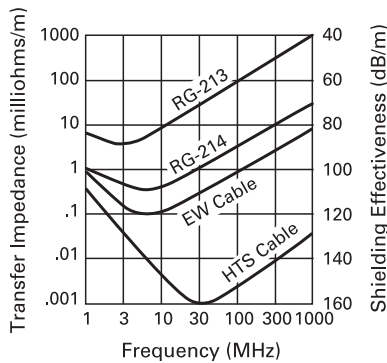

Cable Insertion Loss

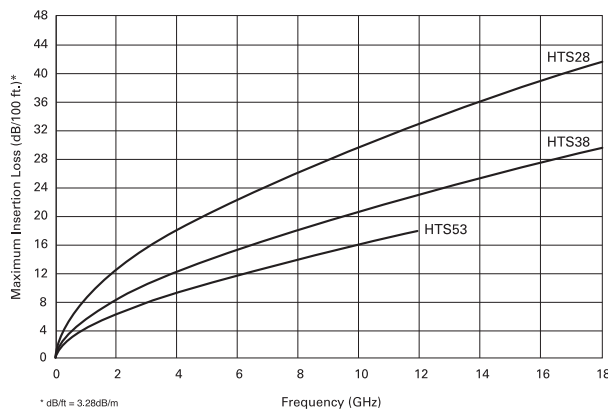

Name	OD (in.)	FCO (GHz)	Fass'y (GHz)	Maximum Insertion Loss: dB/100 ft.							
				Maximum Power Handling (watts)							
				0.1 GHz	1 GHz	2 GHz	4 GHz	8 GHz	12 GHz	18 GHz	26.5 GHz
FT08	0.08	50	3	10.7	32.3	45.8					
<i>Flexible for Gimbal operations (low power)</i>				554.7	183.3	129.2					
FG09	0.09	74	18	9.7	29.4	41.7	59.4	84.9	104.8	129.5	
<i>Flexible to -100°C</i>				686.2	226.6	159.7	112.1	78.5	63.6	51.4	
FG18	0.18	26.5	18	3.4	10.4	14.9	21.4	31.2	39.0	48.9	
<i>Flexible to -100°C</i>				3945.6	1280.9	896.6	621.5	427.6	342.0	272.5	
FE19LSX	0.19	30	26.5	2.7	8.3	11.8	17.0	24.5	30.6	38.3	47.6
<i>Halogen-free, low smoke, for use in enclosed areas</i>				2236.0	729.0	511.1	355.4	245.6	197.0	157.6	126.8
FS23MX	0.23	30	18	3.2	9.6	13.7	19.7	28.5	35.4	44.1	
<i>Flexible for Gimbal operations (medium power)</i>				3853.8	260.5	884.8	616.7	427.5	343.8	275.7	
HTS28	0.28	26	18	2.8	8.7	12.5	18.1	26.4	33.1	41.7	
<i>High tech shielding for EMP protection</i>				7269.7	2380.0	1662.7	1148.3	786.0	626.4	496.9	
FE32LSX	0.32	18	18	1.6	4.9	7.0	10.1	14.5	18.1	22.5	
<i>Halogen-free, low smoke, for use in enclosed areas</i>				6288.0	2057.5	1444.6	1007.2	698.4	561.9	450.7	
HTS38	0.38	18	18	1.9	5.8	8.4	12.3	18.3	23.2	29.6	
<i>High tech shielding for EMP protection</i>				15140.2	4812.7	3342.5	2282.6	1539.6	1214.0	951.4	
FNS0V	0.48	12	6	1.5	4.8	6.9	10.3	15.5	19.9		
<i>High power, highly flexible</i>				27294.5	8525.7	5883.8	3970.7	2637.5	2057.8		
FN98V	0.98	5	5	0.6	2.0	2.9	4.5				
<i>High power, highly flexible</i>				122938.4	36347.2	24613.0	16050.9				
HTS53	0.53	12	12	1.4	4.3	6.3	9.3	14.0	18.0		
<i>High tech shielding for EMP protection (lower loss)</i>				28932.1	9037.2	6236.9	4208.9	2795.8	2181.3		
TRX21	0.21	60	18	9.5	29.7	42.6	62.0	91.2	115.0	145.8	
<i>Triaxial, extra shielded</i>				1633.6	523.8	365.0	250.7	170.5	135.2	106.6	

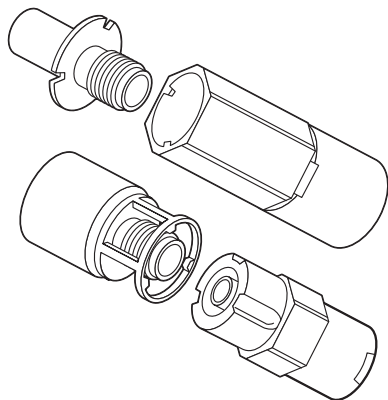

Keyed Connectors

Applications in which multiple cable assemblies with identical connector interfaces must be coupled and de-coupled frequently may be subject to mistakes due to erroneous connections. There are several ways to overcome this problem. With the addition of markers, labels (tags), etc., the problem is minimized. But sometimes, because of the difficulty of reading the labels, a different, more foolproof solution is required. A useful solution is a keyed connector arrangement that allows only the correct connector pair to be mated. This feature is particularly useful in applications in which wrong connections may cause significant system level damage.



Nuclear, Biological and Chemical Contamination Survivable (NBCCS) Cable Assemblies

Cobham has developed the capability to design and manufacture our RF cable systems designed to withstand hazardous conditions that include nuclear, biological and chemical (NBC) contamination. This NBC capability is provided by the Raychem Heat Shrinkable NBCCS system of tubing and molded parts used with Cobham RF cables. A NBC contamination-survivable cable assembly is hardened against NBC contaminants and decontaminants. It can also be decontaminated and is compatible with individual protective equipment.

In designing, evaluating, or specifying NBCCS systems, there are three main criteria to consider:

- Compatibility – The ability of the system to be operated , maintained and re-supplied by personnel wearing full NBC protective gear
- Hardness – The ability of the system to withstand the effects of chemical warfare agents and the decontamination process
- Decontaminability – The ability of the system to be decontaminated to negligible risk levels, allowing personnel to handle it without protective gear

Each NBC cable assembly has been thoroughly tested to exposure from chemical agents, using Army TOP 8-2-511 for interior exposure at 1g/m2 and exterior exposure at 10g/m2. In addition, the systems are rugged to provide protection against physical abuse, resistance to common vehicular, and aerospace fluids and temperature extremes.

Phase and Amplitude-Matched Cables

We have extensive experience in the design and manufacture of phased and amplitude-matched cable assemblies for use in a broad range of applications. We fabricate and store reference standards. In many cases, our existing cable designs will satisfy the requirement. When necessary, a new cable can be developed to meet the specific application.

For phase sensitive applications, Cobham has a dedicated temperature-and humidity-controlled facility in which we assemble and test all high precision phase-matched cable assemblies. This facility includes three HPS510 vector automatic network analyzers.

Precise temperature and humidity control allows us to establish an unmistakable reference baseline for all tests related to phase. This dedicated facility is used for both development and high-volume production of cable assemblies.

The primary benefits of such a dedicated facility include unambiguous results and prompt delivery of cable assemblies that meet the most demanding state-of-the-art requirements (electrical, mechanical, and environmental, such as those found in MIL-DTL-87104 or MIL-T-81490.)

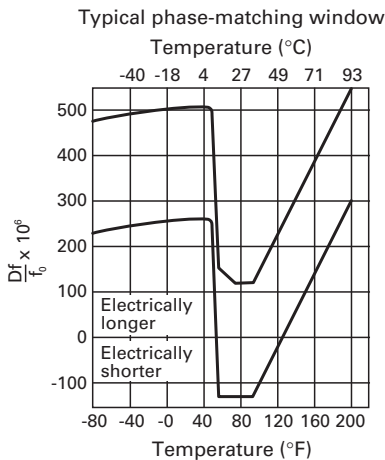

SL Multi-port Interconnection System

The SL (spring-loaded) multi-port connector is a specially developed coaxial interface system designed to satisfy high-performance interconnections not previously achievable with multi-port connectors. The SL connector conforms to such stringent cable assembly specifications as MIL-T-81490 and MIL-DTL-87104. There is no performance degradation when SL cable assemblies are exposed to harsh environments such as extreme vibration, shock, temperature and humidity levels. The SL interconnect system is presently used on several defense

applications. To enhance the utility of the SL interconnector system, the following features have been incorporated:

- Each cable assembly is individually sealed.
- In the field, individual cable assemblies are inserted and removed easily from the rear of the housing.
- A single housing can accept transmission lines of different cable sizes.
- Low VSWR and insertion loss to 18.5 GHz.
- A complete family of compatible interface test adapters, terminations, and “pigtail” assemblies are available.

Housing is available in several configurations. All ports need not be used, but could be available for future additional cables. Other configurations are available upon request.

Rack and panel or thumbscrew mounts are available for securing the connectors.

Assemblies with contacts for ARINC and MIL-DTL-38999 housings

Cobham had developed contacts for use in readily available housings to provide low loss multi-port harnesses for less demanding airborne and ground environments.

Assemblies with Size 8 and Size 12 contacts (usually used on FA19RX cable) are available for use with M38999 housings for broadband operation in a small convenient package. Multi-port harnesses incorporating these Cobham precision contacts provide reliable operation to 18 GHz with a low VSWR comparable with that of individual assemblies. Installation and removal is accomplished with standard M38999 tools. Cobham can provide individual assemblies or complete multi-port assemblies. One caution: these precision contacts cannot be mated with commercially available M39029 coaxial contacts.

Assemblies with Size 1 and Size 5 contacts are used with ARINC housings to provide reliable operation in commercial and military aircraft for critical applications such as TCAS and Mode S.

If you need a multi-port harness, contact Cobham.

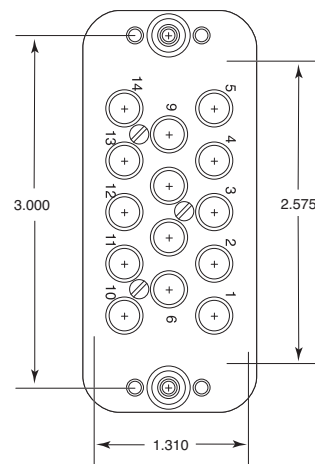
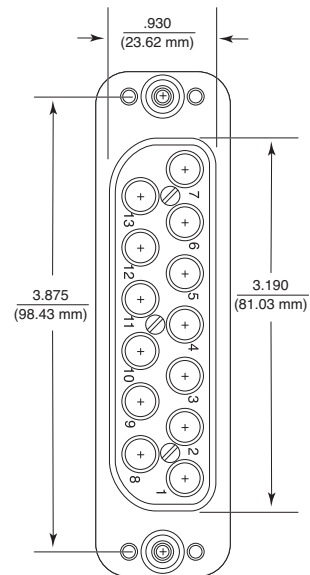

Radiating Cable Antenna Systems

Cobham has developed a series of Radiating Cable Antenna Products which are designed to replace conventional antennas for applications that require very wide bandwidths or physical spaces that provide extreme challenges to traditional antenna solutions. These unique antenna assemblies use a special coaxial cable construction which includes radiating apertures in the cable outer conductor. The amount of radiation can be controlled by adjusting the aperture parameters, allowing for performance to be easily tailored for application specific requirements.

Cobham's Radiating Cable Antennas operate over broad frequency ranges and they can be used for transmit (Tx), receive (Rx) and simultaneous Tx/Rx applications. The antenna construction is rugged and is suitable for airborne, vehicular or ground fixed applications. Antenna lengths are available up to 200 feet. These products are designed to address a wide range of system applications and environments. The low weight and small bend radius simplify installation. Consult your local representative or our factory based application engineers for additional technical information.

Waveguide Interfaces on Cable Assemblies

For critical system requirements it is appropriate to select a direct cable-to-waveguide transition at one or both ends of the cable. When these are compared to cable assemblies with coaxial connectors followed by a coaxial connector to waveguide transition, there are measurable improvements in insertion loss and VSWR. These improvements are due to the elimination of the coax-to-coax interface since the cable transitions launch directly into the waveguide.

Moreover, the installation of the cable assembly becomes easier, and there are fewer parts to buy and to inventory in the system.

Self Lock Connectors

Self lock connectors are the solution when the connection is difficult to get at, or even more difficult to secure with tie wire. They eliminate the need for safety wires, saving time during the initial build cycle and whenever equipment is removed or replaced for service. The use of self locking connectors does not result in an increase in either VSWR or insertion when compared to an assembly using tie wire connectors. The envelope dimensions and mass are close to traditional connectors and the ability to function without degradation in harsh environments has been maintained. A positive lock for the locking mechanism provides both visual and tactile indication when the mechanism is engaged.

The self locking mechanism is available on TNC, ETNC, SMA, Type N, and SC connectors and can be provided on assemblies with any compatible cable size.

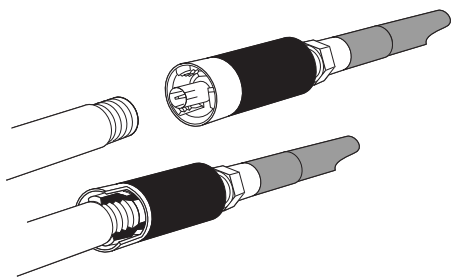

The insertion loss and VSWR specifications of a cable assembly are determined by considering the effect of both the cable and the two connectors. The specifications as quoted are maximum values and are recommended to ensure the most cost-effective production rates. In many cases, tighter performance can be guaranteed, depending on operating band width, connector types, and cable assembly length.

To compute cable assembly insertion loss, determine the following:

1 Insertion Loss due to Cable

Multiply the insertion loss per foot (meter) for the cable type selected by the length of the cable in feet (meters). See curve (data) for each cable type.

2 Insertion Loss due to Connector

Based on the connector styles selected, find the insertion loss of each connector from the table below.

Connector Insertion Loss (db/connector)

Frequency (GHz)	Straight non-replaceable	Straight replaceable	Replaceable or non-replaceable angle
0.03	0.025	0.04	0.05
0.3	0.03	0.05	0.07
1	0.035	0.06	0.075
2	0.04	0.06	0.08
4	0.05	0.07	0.095
5	0.055	0.09	0.10
8	0.065	0.105	0.12
10	0.08	0.11	0.135
12	0.08	0.12	0.14
16	0.10	0.15	0.20
18	0.11	0.16	0.22
26.5	0.14	+	+
40	0.17	+	+

+ Consult factory

3 Insertion Loss due to VSWR mismatch

The VSWR specification is dependent on frequency and connector styles.

Using the table below, determine the VSWR for your cable assembly.

Frequency range (GHz)	Cable assembly with straight non-replaceable	Cable assembly with mixed* connectors	Cable assembly with 2 angles or replaceable connectors
2 to 4	1.20:1	1.25:1	1.30:1
4 to 8	1.25:1	1.30:1	1.35:1
8 to 12	1.30:1	1.35:1	1.40:1
12 to 16	1.35:1	1.40:1	1.45:1
16 to 18	1.40:1	1.45:1	1.50:1
18 to 26.5	1.50:1	+	+
26.5 to 40	1.60:1	+	+

+ Consult factory

* One replaceable straight or one angle connector and the other non-replaceable

Based on the VSWR of the cable assembly, determine the insertion loss contribution from the table below:

VSWR	Insertion Loss
1.20:1	0.04
1.25:1	0.06
1.30:1	0.07
1.35:1	0.10
1.40:1	0.12
1.45:1	0.15
1.50:1	0.18
1.55:1	0.21
1.60:1	0.24

4 The cable assembly insertion loss is equal to the sum of:

- Insertion loss due to cable (1) and the
- Insertion loss due to connector at one end (2) and the
- Insertion loss due to connector at other end (2) and the
- Insertion loss due to VSWR mis-match (3)

A free cable design program CD is available that will perform all of these calculations.

The connectors shown here are representative of the over 5000 that are available from Cobham. These are just a few of the most commonly used and they include envelope dimensions for planning purposes. All connectors are developed in-house and are designed to comply with the interface requirements of MIL-T-81490, MIL-PRF-39012, MIL-DTL-87104, and MIL-STD-348, as applicable. Custom designs are available upon request.

SC and 7-16 IEC for cables from 0.4" OD to 0.6" OD

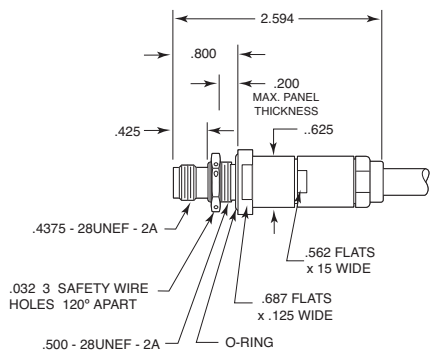
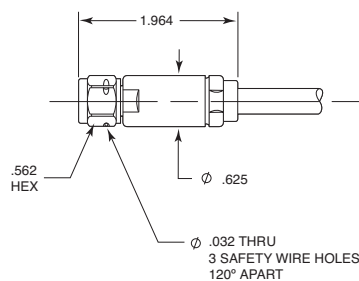
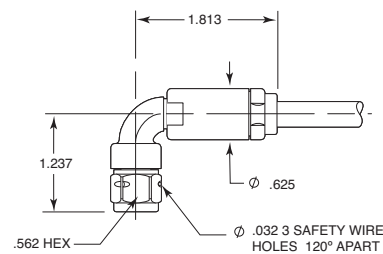
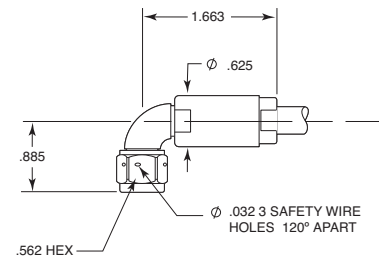
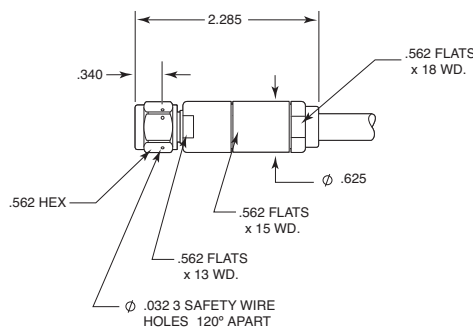
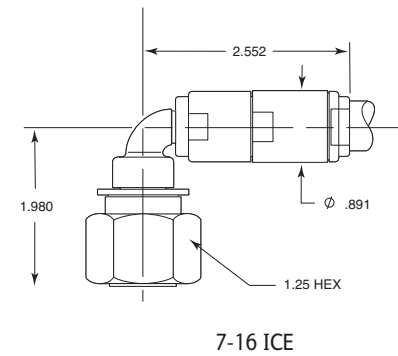
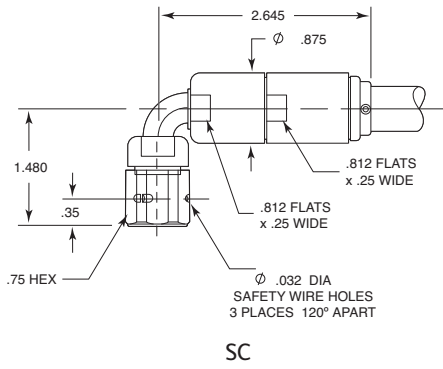
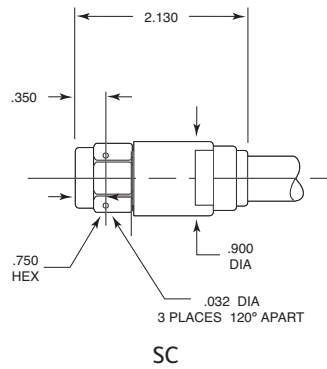
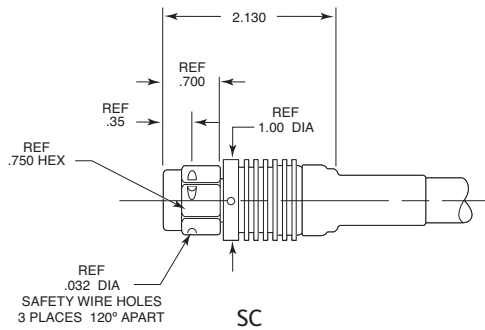

SMA for cables from 0.19" OD to 0.25" OD

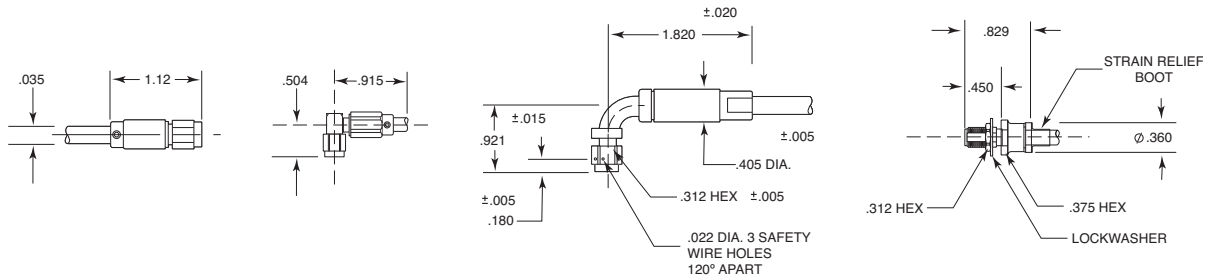

GPO for cables from 0.07" OD to 0.11" OD

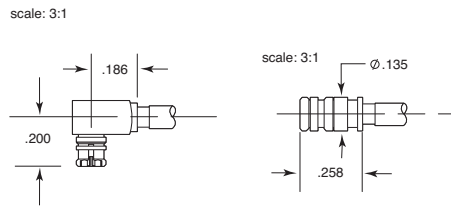

Cobham also supplies cable assemblies with customized flange-mounted launchers for direct attachment to your component. Alternatively, cable assemblies can be supplied with the braid layers stripped and tinned.

This application note elaborates on the power handling capability of some of the cables presented in this catalog. The matrix of average power over frequency provided for each cable type is to be used as a guideline. To deal with demanding applications, review this section.

Peak and average power

There are two potential failure modes in cables used to transmit high peak power. One is voltage breakdown; the other is overheating. The major concern associated with application of peak power is breakdown due to high potential. By themselves, the cable and the connectors may break down under high voltage due to peak power. However, the cable-to-connector junction is the one location on the cable assembly most sensitive to high potential breakdown.

Prudent design of overlapping dielectrics and proper selection of connector type, combined with actual high potential or severe requirements testing, ensures that breakdown will not occur. Another consideration in pulsed systems is overheating due to CW power.

Average (CW) power handling capability

The major effect of average power in cable assemblies is the generation of heat from power dissipation and the resultant temperature rise. Many factors are involved in determining this effect for a particular cable assembly, but a short discussion may help distinguish the many facets of the problem.

In all cases, the limit of CW power level is reached when the hottest surface temperature (measured anywhere on the cable assembly) has reached a predetermined temperature, T_{max} . For most high performance high power cable assemblies, T_{max} is on the order of 400°F (204°C). This temperature is chosen based on explosive atmosphere mil spec requirements and also because higher temperature starts to soften the dielectric used in most cables. The temperature T_{max} usually occurs near or on the connector nearest the source. For different types of cables, the tolerance temperature unit that a component within that cable will withstand determines T_{max} . Expressed differently, one may allow T_{max} to increase up to the limit of initial damage to the most sensitive component within the cable.

Connectors as a limiting factor

Heat generation in a connector is analyzed by examining the center conductor diameter “a” of the connector involved. Generally, if the diameter of the center conductor of the cable is approximately the same as the dimension “a” of the connector, the surface temperature at the connector and of the cable next to it will be about the same with power applied. Choice of a small connector for use with a large cable will make the connector hotter than the cable.

The data presented in this catalog include a safety margin (SM). This SM will allow operation of cable assemblies at the stated average power levels for the length of time called out in the appropriate mil specs. Aging is a process dependent on many variables; among them are ambient temperature, mechanical vibration or flexure, and handling. If one could isolate the aging effect due to the application of power only, the following applies (as for all microwave components): there is a time limit, after which continuing the application of CW power will accelerate the aging of the cable assembly. Power application eventually will affect cable performance. These time limits will vary, depending on consideration of all stresses. Please consult our engineers for any questions regarding the service life during continuous application of power.

Connector	“a” (center conductor diameter)
ETNC	0.085 inch
N	0.120 inch
SC	0.120 inch
SMA	0.050 inch
TNC	0.085 inch

Heat removal

The following is a discussion of heat removal and experimental results obtained at Cobham. Exact mathematical description of the hot cable assembly in terms of heat flow analysis is almost impossible.

Under steady state conditions (typically achieved after about 20 minutes of continuous CW power application), cable assembly has a unique temperature distribution. This distribution is heavily influenced by the installed environment. As in all heat transfer problems, the hot cable assembly gets rid of its heat by conduction, convection, and radiation. Conduction could be the most effective of the three, especially at high altitude where the air is thin. However, because we cannot predict the geometry of bulkheads and mounting plates in general, this most effective means of heat removal is not included in the power handling data. In fact, the power handling data throughout this catalog relates to a cable that is allowed only convection and radiation for heat removal. While conduction might improve significantly the power handling characteristics of cable assemblies, this note treats any benefit resulting from conduction as an increased safety margin.

Of the two means left for removing heat, convection remains as the more effective, even at high altitude. Cobham has empirical data based on extensive testing of many cable assemblies in our temperature-altitude chamber, while varying the chambers ambient temperature and altitude. These tests were performed on a variety of cable types to generate the power handling and derating data found in the data section of this catalog. The matrix data are a good guide to choosing the right cable for a particular frequency and average power level. (See curves on the following pages.)

Practical consideration

A system application may require all cable assemblies to use ETNC connectors. In addition, the cable chosen may have a center conductor considerably larger than that of the connector. When this is true, the connector will be hotter, perhaps considerably hotter, than the cable. Under these conditions, heat sinking of the connector is recommended; bulkhead connectors or finned heat-sunk connectors are examples of such connectors. Usually, heat sinking is sufficient since conduction is very effective at removing heat. However, if power levels and predicted temperatures are very high, tests should be conducted to verify the design. If you have a high power application and are uncertain how to proceed, call us. We already may have performed the test; or we may have the special connector or cable to suit your needs already designed.

Approximate derating curves

To determine the Derating Factor (DF) at different altitudes or at different ambient temperatures, use the following chart. Based on the listed groups, select the appropriate derating curve. Multiply the average power handling data at the frequency of interest (obtained from the data section of the catalog). The resultant number is the maximum average power handling capability of the selected cable at the selected ambient temperature and altitude. (Derated Average Power = DF x Average Power from data section). Derating Information for other conditions or for cables other than those shown is available upon request, please contact us.

Properly de-rated power curves are available from our free cable design program.

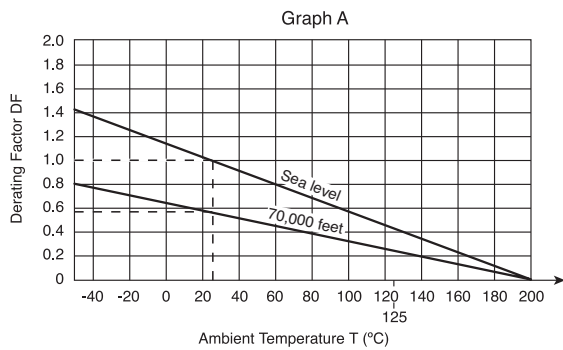

FC15EX, FC17EX, FN17EX, FN19EX, FN22, FN24, FN24RL, FN25, FN27RL, FN32RL, FN35, FN35RL, FN40, FN40RL, FN50, FN52RL, and FN55 cables)

Formula for straight lines (Graph A):
 Sea level DF = (200 - T) (0.0057)
 70,000 ft DF = (200 - T) (0.0033)

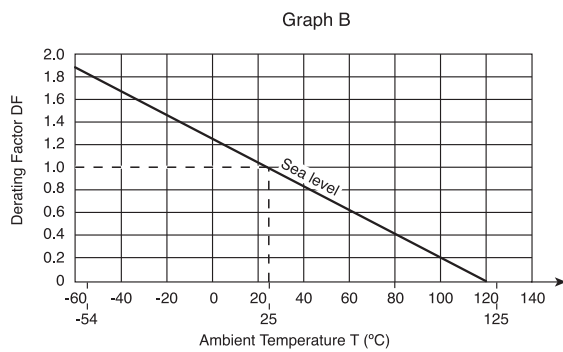

FE10ST, FE12ST, FE15ST, FE19ST, FE25, FE35, FE47, FES2, FE56, FE81, and FE92 cables)

Formula for straight line (Graph B):
 DF = (125 - T) (0.0105)

Example:

Determine the average power handling capacity of FN35RL at 18 GHz at 70,000 ft and 100°C ambient.

The DF is 0.333 (from Graph A).
 DF = 200 - 100) (0.0033) = 0.33

The power handling at room temperature selected is 980 watts. 980 x 0.333 = 326 watts

Data at sea level, 25°C given in graphs.

Maximum Allowable Power Handling
 (watts average at 70,000 ft, 100°C ambient)

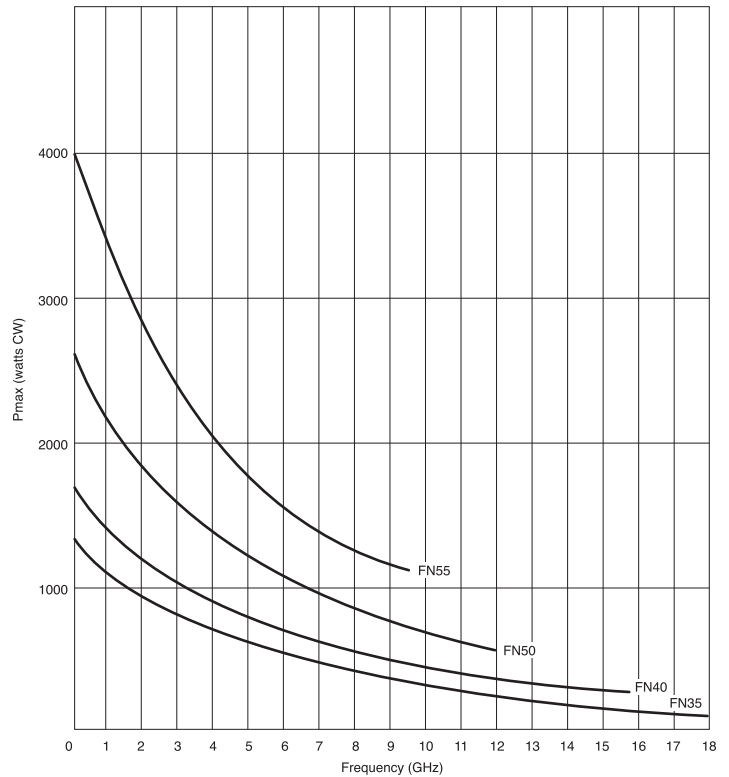

Maximum Allowable Power Handling
 (watts average at 70,000 ft, 100°C ambient)

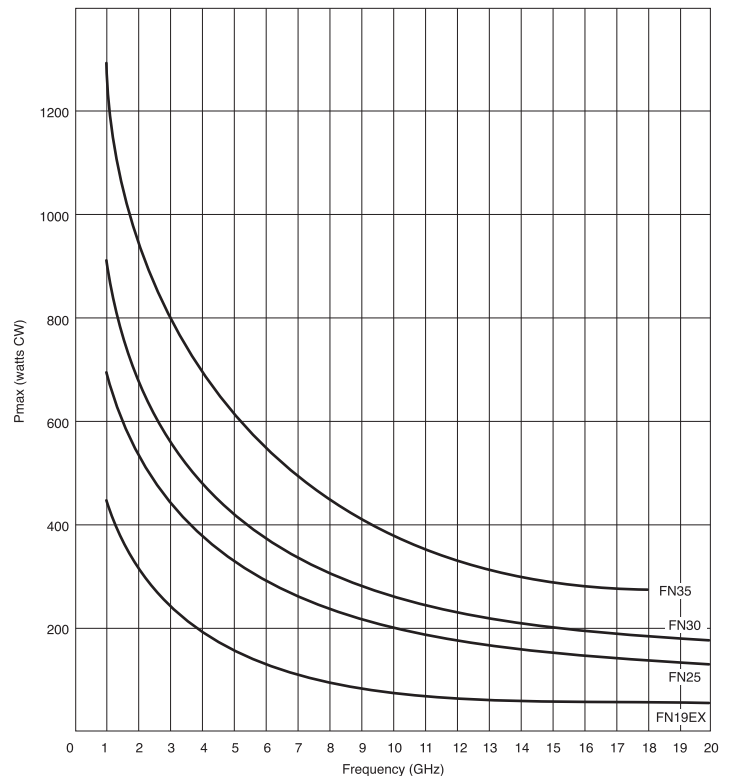

Securing the connector interface: do not use pliers!

To ensure proper thread engagement and minimize the chance of cross-threading, first finger tighten the connector interface. Most connectors are provided with wrench flats. A torque wrench should be used to tighten the connectors to the torque specified, insuring uniform repeatable connections. When tightening, turn only the coupling nut, preventing the connector body and the entire cable assembly from rotating.

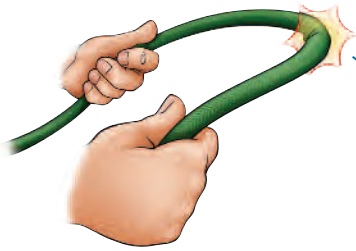

Maintain as large as bend radius as possible

When using the cable in a confined area, maintain as large a bend radius as possible. A large radius reduces wear on the cable, and minimizes the electrical phase shift changes introduced by bending. If possible, form the bend over a smooth surface. Never crimp or kink the cable. The bend radius should not be less than 5 times the cable diameter. A smaller bend radius may cause changes in impedance and possible permanent degradation in electrical performance.



Special handling

- Don't expose cable to temperatures beyond specs.
- Don't use the cable assembly as a tow rope or suspension wire. Use Kellems grip to move cables (especially longer lengths).
- Don't stand on cable.
- Don't place or drop heavy equipment on cable. When the cable is subjected to localized compressive forces, the circular cross section of the cable is distorted, changing the characteristic impedance and thus VSWR.
- Do inspect the cable assembly regularly.
- Never route the cable over sharp metal surfaces which could cut into the RF coaxial cable.
- Choose proper diameter cable clamps that do not "crimp" the cable.

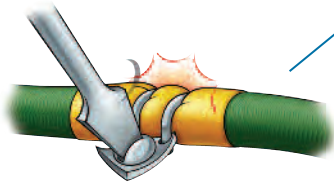

The connector interface

Keep the connector interface clean to minimize wear and maintain performance. A non-linting swab or soft brush dipped in alcohol is the simplest and preferred method of cleaning the interface. Do not use Halide cleaners because they damage the support bead used in 7-mm connectors. Chips or foreign matter may be blown out of the interface with dry, non-oily compressed air. Be sure the cleaning agent has evaporated before proceeding to mate connectors.

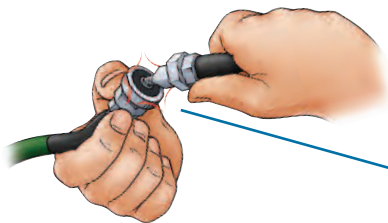

For long life and consistent performance

- Don't poke screwdrivers or other tools into connector interfaces.
- Check the pin height regularly. Refer to MIL-PRF-39012 and MIL-STD-348 for proper dimensions. An out-of-tolerance pin height is a sign of a damaged connector, which should be replaced.
- When mating two connectors, do not cross-thread the coupling nut. Cross-threading damages the threads and/or breaks the contact finger tangs and is a common cause of connector failure. If difficulty is encountered when making a connection, remove the cable assembly, identify the problem, and correct it.

In order to qualify for use in electronic warfare and other demanding applications, most of our high performance cable assemblies must pass a rigorous set of environmental tests. These include:

Requirement	Test Limits and Method
Abrasion resistance	per MIL-DTL-87104
Acoustic noise	159 dB per MIL-STD-810 Method 515
Chemical resistance	cleaner-brightener, JP-fuels, epoxy stripper, hydraulic fluid, and coolanol per MIL-T-81490, ASNAE-68-38, & MIL-DTL-87104
Concentrated load	100 lbs per MIL-T-81490 and MIL-DTL-87104
Explosive atmosphere	Explosion free to 70,000 ft per MIL-STD-810 Method 511
Flammability	Exposure of 30 sec, extinguish in 6 sec per MIL-STD-202 Method 111
Humidity	240 hrs per MIL-STD-810 Method 507
Salt fog (corrosion)	168 hrs at 35 C per MIL-STD-810 Method 509
Sand and dust	Velocity of 2000 ft/mm per MIL-STD-202
Sealing	Water immersion with air evacuated to 70,000 ft per ASNAE-68-38
Shock (impact)	4 in drop test per MIL-T-81490 and MIL-DTL-87104
Shock (thermal)	-65°C to +200°C per MIL-STD-202 Method 107
Temperature altitude	-54°C to +200°C per MIL-T-81490
Vibration	5 to 2000 GHz at 15 g per MIL-T-81490

Many test reports for each cable type with different connectors are available upon request.

To inquire about, or order, a particular cable assembly, please describe it by constructing its part number. Use the appropriate tables that follow for Electronic Warfare, Space, Laboratory, and Commercial Aviation products found on pages 22 to 47. Or, you may choose to use the custom cable assembly requirements form. To use this form, make a photocopy of page 72 and fill in the blanks. Not all cable-connector combinations are available.

High Performance EW and Laboratory Cable Assemblies

The example below illustrates the part number formulation for a cable assembly using FE19 cable, 36 inches in length, with a SMAMNR at one end and a SMAM90NR boxed connector at the other end and no clocking required, to operate up to 18 GHz.

Cable Codes

Cable Type	Code
FE10ST	E10
FA12RX	B12
FA12X	A12
FE12ST	E12
FE12RL	D12
FE15ST	E15
FC15EX	C15
FN15TF	T15
FN17EX	N17
FC17EX	C17
FA19RX	B19
FA19RXLW	K19
FA19X	A19
FN19EX	N19
FN19TF	T19
FE19RL	D19
FE19ST	E19
FA20RX	B20
FA20RXLW	K20
FN22	N22
FN22RX	W22
FN22X	X22
FN24RL	R24
FE24	E24
FN24	N24
FE25	E25
FN25	N25
FN27RL	R27
FA29RX	B29
FA29X	A29
FA31RXLW	K31
FN32RL	R32
FN34RX	W34
FN34RXLW	M34
FN35RL	R35
FE35	E35
FN35	N35
FN40	N40
FN40RL	R40
FE47	E47
FA46RX	B46
FC48Z	Z48
FN49RX	W49
FN49RXLW	M49
FN50	N50
FN52RL	R52
FE52	E52
FN55	N55
FE56	E56
FN61	N61
FE81	E81
FE92	E92

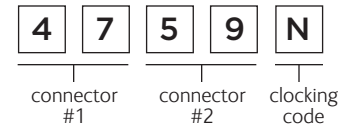
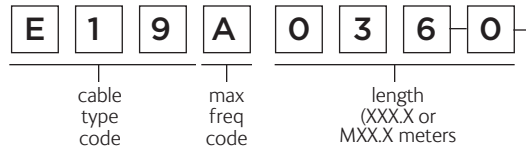

Connector Codes*

Type	Replaceable	Non-Replaceable
2.4 mm f	16	58
2.4 mm m	15	57
3.5 mm f	11	53
3.5 mm f ruggedized	12	54
3.5 mm m	10	52
7 mm	04	48
ARINC 600 Series	29	71
Cm	28	70
Cm 90°	27	69
ETNCm	01	45
Kf 2.92 mmf	14	56
Km 2.92 mm m	13	55
Nf	09	51
Nf BHD	26	68
Nm	02	46
Nm 90°	25	67
SMAf	07	49
SMAf BHD	20	62
SMAM	03	47
SMAM90 Boxed	17	59
SMAM90 Swept	18	60
SMCM	19	61
TNCf	08	50
TNCf BHD	23	65
TNCm 90°	22	64
ETNCm 90°	42	86
TNCm	43	87
7-16 IECm	44	88
Nm 90° (knurled)	89	—
Nm Knurled	05	90
TRm	30	72
TRf	31	73
LCm	40	79
7-16 IECm 90°	41	—

Connector Codes

Type	Replaceable	Non-Replaceable
SCm	32	74
SCf	33	75
3.5mm m 90°	34	76
BNCm	38	80
BNCf	39	81
Low Cost SMAM		83
Low Cost TNCm		84
Low Cost Nm		85
7-16 IEC F		91
LTm		92
Low Cert G7WC m		93

Maximum Operating Frequency Code

Range (GHz)	Code
2	V
5	W
8	X
10	Y
12	Z
18	A
26.5	B
40	C
50	D
cable or connector upper frequency	F*

* See pages 17-21 for upper frequency limits.

Clocking Codes

Angular position of connector #2 in reference to connector #1 when two angled connectors are specified.
 N-None Required
 Z-0°
 Y-90°
 X-180°
 W-270°

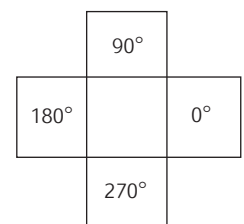

* Not all connector types are offered on all cable types. Generally, cables with an OD less than 0.22" are not offered with replaceable head connectors.

If you have any questions, please call us at the phone number listed on the back cover. Our sales engineers and advanced development engineers are prepared to help you define the product, provide a quotation, or accept an order.

General Test Cable Assemblies — 18 and 26.5 GHz

The example below illustrates the part number formulation for a FN24G cable, 24 inches long, with 3.5 mm female and 3.5 mm male connectors.

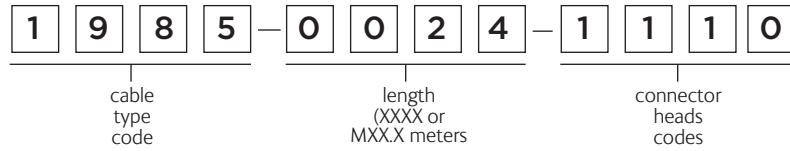

Cable Codes

Type	Maximum Frequency	Code
FN24G	26.5	1985
FE19	18.0	1993*
FE25G	18.0	1996
FN25G	18.0	1999
FN25GA	18.0	1998
FC32G	18.0	1992
FN35G	18.0	1997

18 GHz Accessories

	Part Numbers
Interlink	1600-8207
90° Interlink	1600-5136
Storage Box	9604-0250
Torque Wrench	9604-0251
Flat Wrench	9604-0321
Test Kit	9613-0001
Contains:	
2 each: ETNC p, SMA p, N p, & 7mm.	
1 each: flat & torque wrench	

26.5 GHz Accessories

	Part Numbers
Storage Box	9604-0250
Torque Wrench	9604-0372
Flat Wrench	9604-0295

* 1993 Series is offered only with N p, ETNC p and SMA p non-replaceable connectors.

Connector Head Codes: 18 GHz only ▲**

Type	On Cable Assemblies	For Separate Purchase
ETNC p	01	1550-0067
TNC j	08	1550-0165
N p	02	1550-0068
N p (knurled)	05	1550-0117
N j	09	1550-0166
SMA p	03	1550-0070
SMA p (knurled)	06	1550-0118
SMA j	07	1550-0164
3.5mm p	10	1550-0168
3.5mm j	11	1550-0167
7mm	04	1550-0069

Connector Head Codes: 26.5 GHz only ▲**

Type	Maximum Frequency	On Cable Assemblies	For Separate Purchase
ETNC p	18	01	1550-0389
TNC j	18	08	1550-0390
N p	18	02	1550-0392
N j	18	09	1550-0393
SMA p	26.5	03	1550-0384
SMA j	26.5	07	1550-0385
3.5mm p	26.5	10	1550-0386
3.5mm j	26.5	11	1550-0387
7mm	18	04	1550-0391
K p	26.5	13	1550-0398
K j	26.5	14	1550-0399
2.4mm p	26.5	15	1550-0603
2.4mm j	26.5	16	1550-0602

** 18 GHz connector heads are not interchangeable with 26.5 GHz connector heads.

▲ Replaceable heads with integral rotary adapters are also available. Please contact us for part numbers and data sheets.

If you have any questions, please call us at the phone number listed on the back cover. Our sales engineers and advanced development engineers are prepared to help you define the product, provide a quotation, or accept an order.

Phase Stable Test Cable Assemblies — 26.5 and 40 GHz

The example below illustrates the part number formulation for a phase stable test cable type 2025, 24 inches long, with a 7 mm connector at one end and a 3.5 mm male connector at the other end.

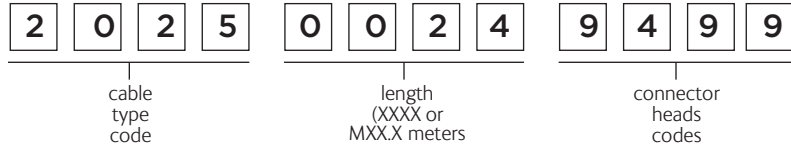

Cable Codes

Type	Maximum Frequency	Code
2025	26.5	2025
2026	26.5 ▲	2026
2050	50.0 ▲*	2050

Accessories

	Part Numbers
Flat Wrench	9604-0925
Torque Wrench	9604-0925

* 2050 Series is offered with nonreplaceable 2.4 mm p and 2.4 mm j plus 2.4 mm j ruggedized
 ▲ 2026 and 2050 Series have armor jackets protected by a silicone jacket

Connector Head Codes[‡]

Type	On Cable Assemblies	For Separate Purchase
ETNC p	91	1550-0229
TNC j	90	1550-0230
N p	93	1550-0249
N j	92	1550-0250
SMA p	97	1550-0197
SMA j	96	1550-0198
3.5mm p	99	1550-0226
3.5mm j	98	1550-0227
3.5mm j ruggedized	95	1550-0228
7mm	94	1550-0246
K p	89	1550-0362
K j	88	1550-0363
2.4mm p	87	1550-0457
24mm j	86	1550-0458
2.4mm j ruggedized	85	1550-0459
1.85mm j		NA
1.85mm j		NA

[‡] Replaceable heads with integral rotary adapters are also available. Please contact us for part numbers and data sheets.

Test Kit Contents

Item Description	Part Number	P/N 9613-0016 Kit 1 Quantity	P/N 9613-0028 Kit 2 Quantity	P/N 9613-0053 Kit 3 Quantity	P/N 9613-0054 Kit 4 Quantity	P/N 613-0055 Kit 5 Quantity
Cables						
2025, 24 inch long	2025-0024	2	2	0	0	0
2026, 0.5 meter long	2026-M005	0	0	2	2	0
2026, 1.0 meter long	2026-M010	0	0	0	0	2
Connectors						
TNC female R	1550-0230	0	1	0	0	0
TNC male R	1550-0229	0	1	0	0	0
N female R	1550-0250	0	1	0	0	0
N male R	1550-0249	0	1	0	0	0
7mm R	1550-0246	2	2	2	2	2
SMA female R	1550-0198	0	1	0	0	0
SMA male R	1550-0197	0	1	0	0	0
3.5mm female R	1550-0227	1	1	1	1	1
3.5mm male R	1550-0226	3	1	3	3	3
Ruggedized 3.5mm female R	1550-0228	2	2	2	2	2
Accessories						
Flat Wrench	9604-0295	1	1	1	1	1
Torque Wrench	9604-0251	1	1	1	1	1

Cable Assembly Characteristics

The flexible cable assembly best suited for your needs will offer nominal insertion loss consistent with smallest size and weight without sacrificing flexibility. Other parameters will influence its performance and price.

These include such mechanical performance as abrasion resistance and connector retention strength, or such environmental performance as ability to operate at high altitude or in space, at high temperatures with high humidity, etc. One critical factor is HF leakage or EMI suppression.

Low insertion loss	Function of connector (straight, angled, or replaceable) and cable.
High breakdown potential	Function of connector and connector-to-cable junction.
Humidity seal	Function of connector, cable, and connector-to-cable junction.
Good phase/amplitude stability	Function of cable and connector-to-cable junction.
High power handling	Usually limited by connector. Function of connector and cable selected.
Low RF leakage	Better than -90 dB/ft (-84 dB/m) measured per MIL-T-81490 (for standard cable types). See page 50 for information regarding HTS (High Technology Shielded) cable (it offers -140 dB/ft [-134 dB/m]).
Low VSWR	Function of connector (straight, angled, or replaceable) and cable.

Cable Selection Criteria

Environment	Consult the section on cables on pages 17-21 to select the proper insertion loss and outside diameter. Check the data section for other specifications relevant to your needs. Listed below are some criteria.
Flexibility	Severe mechanical stresses (abrasion, compression, pull, torque, etc.) dictate use of FN (Nomex jacketed) type cables. FM type cables are also recommended for applications exposing cable to chemicals, fuels, salt spray, etc. For given power level but higher temperatures and/or altitudes, larger diameter cables will be necessary.
Frequency range	The more flexibility required, the smaller the cable should be. Cable construction will affect flexibility and endurance to repeated flexure. At the low end, all Cobham cables work to DC. At the high end, the cutoff frequency limit determines the maximum cable size.
Insertion loss	For lower insertion loss, select larger diameter cable. The higher the frequency, the smaller the diameter and the higher the insertion loss. For a fixed outer diameter, the lower the dielectric constant, the lower the loss.

Cable Selection Criteria (continued)

Power handling Peak power handling is independent of frequency. Average (CW) power handling is inversely proportional to frequency. For greater power levels, select the larger outer diameter cables.

Price FC (extruded FEP outer jacket) or FE (Elastomer jacketed) cable is usually less expensive than FN (Nomex jacketed) cable. Smaller diameter cables are more cost effective than larger cables.

Weight The lighter the cable, the smaller the size.

V_p refers to the velocity of propagation of a signal through the cable. It is expressed as a percentage of the speed of light. Most common cable with Teflon wrapped dielectric exhibits a V_p of 76%; i.e., the signal will travel through the cable at 0.76 of c (3×10^8 m/s) or at 2.28×10^8 m/s.

This property is significant when time delay is critical. The capacitance associated with a given V_p will determine the level of distortion of a pulse traveling through the cable. Increase in V_p reduces capacitance and the associated distortion.

V_p (%)	70	76	80	82
Time delay (ns/ft)	1.45	1.34	1.27	1.24
Capacitance (pf/ft)	29	27	25.5	25

Consequently, for those applications in which high fidelity of pulse is necessary, a high V_p cable is recommended. It is important to note that high V_p ("fast") cable will have an increased amount of air trapped in the dielectric. This air tends to make the cable softer and thus more susceptible to damage as a result of pressure. To reduce such a sensitivity, different types of armoring (stainless steel, spiral spring, etc.) may be considered.

Cable Selection Criteria (continued)

To achieve the lowest insertion loss and greatest power handling capability, the connectors should be as large as possible. However, they must not be so large that they can support higher-order modes. Heavy connectors also may damage and/or fall off the cable from their own weight. As a general guide, the inner diameter of the outer conductor should be approximately the same size as the cable outer braid. TNC and N are good choices for 0.350 in. (8.89 mm) OD cables, and SC is a good choice for 0.5 in. (12.7 mm) cables.

Cable size selected	Must be close in size: i.e., SMA is not recommended on FN55 (0.55 in, [14 mm] OD).
Form factor	Straight, angular, keyed, BlindMate, polarized.
Frequency range	Upper frequency cutoff determines maximum connector diameter (and thus restricts choice of interface).
Moisture protection	Sealed or unsealed?
Power handling	Must be capable of handling desired power—usually connector rather than cable is limitation. Connectors with PTFE dielectric interfaces will handle maximum peak power. Connectors with air dielectric interfaces will handle maximum CW power.
Price	Use of common connectors SMA, TNC, N, ETNC, SC, etc., is less expensive than special or less commonly used types as HN, MSC.
Repairability	Replaceable or non-replaceable? Replaceable connectors are ideal for applications that require a long run of cable in areas difficult to access. If the primary interface is damaged, it may be replaced in the field, eliminating the need to remove and replace the entire cable assembly. Cobham typically recommends replaceable type connectors for assemblies longer than 10 feet.

Recommended Upper Frequencies for Common Connector Types Offered*

Upper Frequency (GHz)	Type
1	HN
1.5	1-5/8 EIA
3	7/8 EIA
4	BNC**
4	C**
4	SMC**
5	LC
5.5	LT, MLT
5.5	Spinner 4-11
7.5	7-16 IEC
8.5	14 mm Precision
12	SC
16	TNC
18	ARBM
18.2	ETNC
18.5	7 mm Precision
18.5, 22	N
22	TR
22	OSP
26.5	SMA (OSM)
28	OSSP
34	SSMA (OSM)
34	3.5 mm Precision
40	OS-50-P
40	2.92 mm (K)
40	GPO (SMP)
50	2.4 mm (OS-50) TM
60	1.85 mm (V)

* Cable type permitting. See pages 17-21 for cable cutoff frequency.

** Restricted due to coupling mechanism.

A one-piece cast tubular construction is impervious to moisture penetration. It is strong yet lightweight. Several angle variations are possible by changing the angle of this elbow. (90° angle shown)

Our high performance EW coupling nuts contain no snap rings. Instead, a positive shoulder threaded arrangement is used to secure the coupling nut to the connector body. Many connectors are sealed independently and are designed to withstand 50 in.-lbs. coupling nut torque. A wide variety of independently sealed replaceable connector heads and intermediate interfaces per MIL-T-81490 are also available.

Silver-coated copper stranded center conductor is used to increase flexibility and flexure life. (Solid center conductors are used on some small diameter and very low-loss cables.)

Various air-spaced, wrapped, Teflon PTFE layers reduce attenuation by providing a low dielectric constant. Solid PTFE is used in some cable types to reduce cost.

1st Shield: Flat, silver-coated copper braid increases cable strength and provides good coverage to minimize RF leakage and insertion loss.

2nd Shield: Metal-backed Polyimide tape is helically wrapped in overlapping layers to reduce EMI (RF leakage).

3rd Shield: Braided, silver-coated copper strands increase strength of the cable and further reduce RF leakage.

1st Jacket: An extruded layer of Teflon FEP or PFA provides a thick, tough barrier impervious to most types of fluids.

2nd Jacket: Overlapped, adhesive-backed Polyimide tape prevents the FEP or PFA from flowing under extremely high temperature conditions. The tape also acts as a redundant moisture barrier.

3rd Jacket: Nomex braid is saturated in Polyimide. It provides abrasion resistance and protects the cable from physical damage.

Contact fingers are constructed with an outward flare and grooves to ensure positive coupling contact with mating components.

The center conductor of the cable is captivated at the cable/connector junction and the connector interior to preclude center pin movement.

All connector interfaces comply with the interface requirements of MIL-T-81490, MIL-PRF-39012, MIL-DTL-87104, and ASNAE-68-38 as applicable. Keyed connectors are available if required.

The elbow/connector interface is sealed with O-rings, and the elbow dielectric is designed to allow controlled expansion during temperature variations. A unique method of attachment is used wherein the outer conductor of the cable is securely fastened to the connector. In addition, the boot is bonded both to the FEP jacket and to the Nomex outer jacket. This bond provides excellent connector retention.

A vulcanizing tape around the cable-to-connector junction provides an additional moisture barrier and pull force resistance. Finally, a Viton boot is installed over the connector back end to provide additional moisture protection and to provide strain relief for the cable-to-connector junction. This boot minimizes the possibility of the connector breaking away from the cable or the possibility of the cable minimum bend radius being exceeded during connect/disconnect. Ask for the application note discussing our cable assemblies in greater detail.

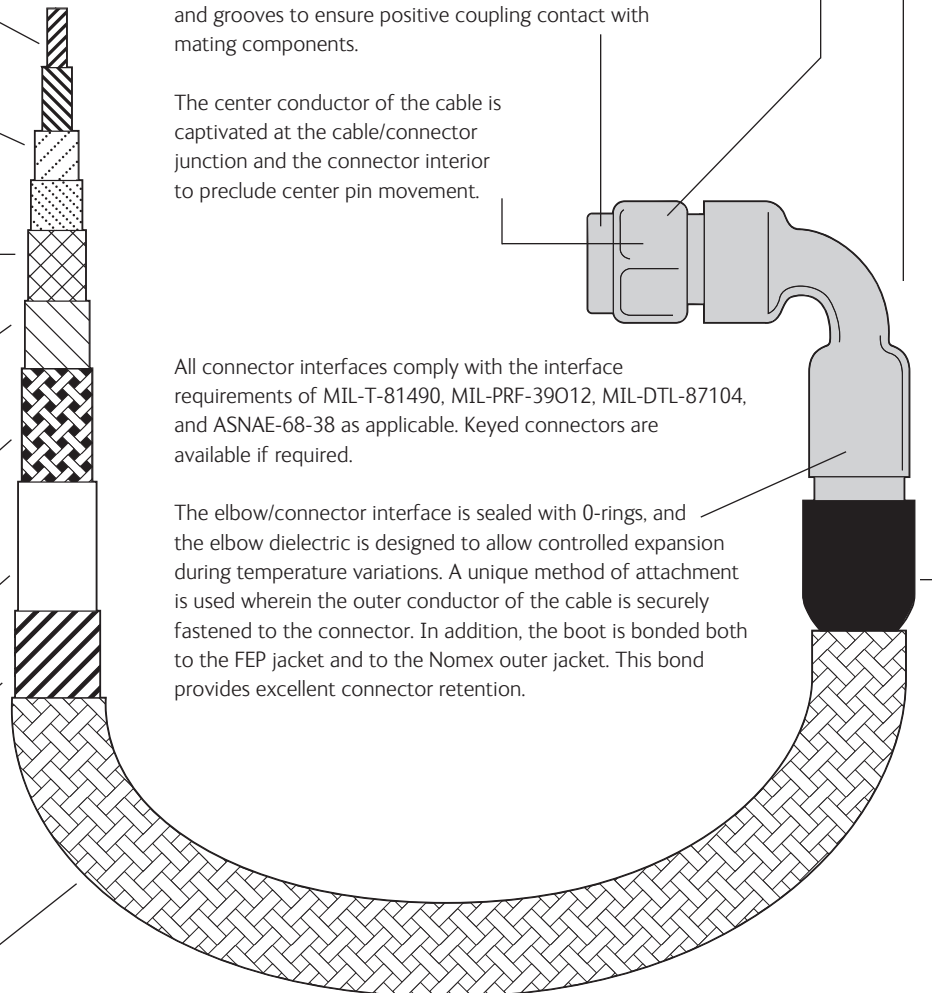

The center pin is constructed of gold-plated beryllium copper. The inner conductor is both threaded and high-temperature soldered to the cable inner conductor to provide a firm, positive mechanical and electrical junction.

Connector outer bodies are made of passivated, corrosion-resistant stainless steel. (Beryllium copper and other materials are used if required.)

All conductor diameter changes are offset to maintain a low VSWR over broad frequency range.

Positive shoulder construction, i.e., threaded or built-in, eliminates snap rings and permits the coupling nut to tolerate higher pull and torque force.

The outer conductor is constructed of silver-plated and rhodium-flashed brass or beryllium copper.

Outer conductor overcuts and inner conductor undercuts prevent relative movement of the cable inner conductor and cable dielectric with respect to the outer conductor.

The two outer conductor braids are clamped, using several alternative clamping mechanisms. Special designs are available to tolerate extreme pull and torque forces.

Many connectors are sealed in the front and rear by O-rings and are reinforced in the rear by a high-temperature epoxy adhesive that also increases resistance to excessive torque and tensile strength limits by bonding the Nomex layer to the conductor.

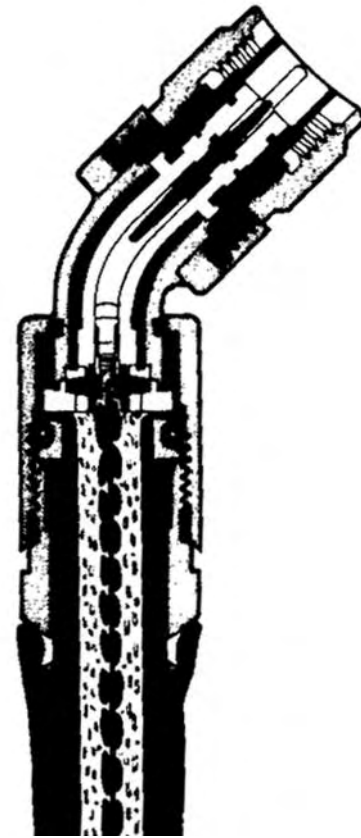

Typical Conductor Weights

Connector	Replaceable		Non-replaceable	
	(lb)	(kg)	(lb)	(kg)
FN50 and FN55				
N & SC straight	0.20	0.09	0.10	0.05
N & SC angle	0.28	0.13		
TNC straight	0.19	0.086	0.08	0.04
TNC angle	0.25	0.11		
HN straight	0.21	0.09		
HN angle	0.29	0.13		
FN30, FN35, FN40				
TNC straight & ETNC	0.12	0.054	0.06	0.03
TNC angle & ETNC	0.20	0.09	0.13	0.059
N & SC straight	0.07	0.032	0.07	0.032
N & SC angle	0.15	0.068		
SMA straight	0.11	0.05	0.06	0.03
SMA angle	0.19	0.086, 0.13	0.13	0.059
FN14EX, FN17EX, FE19ST, FN19EX, FE25, FE25				
TNC straight & ETNC	0.20	0.09	0.06	0.03
TNC angle & ETNC	0.28	0.13	0.13	0.059
SMA straight	0.19	0.086	0.02	0.009
SMA angle	0.25	0.11	0.09	0.04

Characteristics

- Low insertion loss*
- High power handling capabilities*
- Replaceable heads*
- Captivated center contacts*
- Stainless steel housing*
- Molded boots*
- Wide variety of interfaces*

Electrical requirements

Frequency range _____

VSWR _____

Insertion loss _____

Power handling _____

Watts CW _____ Watts peak _____

Other requirements _____

Mechanical requirements

Connector type (1) _____

Connector type (2) _____

Replaceable (1) (yes) (no) _____

Replaceable (2) (yes) (no) _____

Length _____ Max outer diameter _____

Max weight of cable assembly _____

Min bend radius of cable _____

Environmental requirements (operational)

Temperature _____ Sealing _____

Altitude _____ Vibration _____ Shock _____

Other special environmental needs _____

Information

Organization _____

Program _____

Name _____

Phone _____

Quantity required _____ Required delivery _____

Follow-on quantities/delivery _____

Comments (special testing, marking, etc.) _____

Frequency Designations		
Previous	(GHz)	New
	0.1	A
	0.25	B
	0.50	C
	1.00	D
	2.00	E
	3.00	F
	4.00	G
	5.2	H
	6.00	I
	8.00	J
	10.9	K
12.4	10.00	J
18	20.00	K
26	36	L
	40.00	M
	46	
	56	
	60.00	
	100	
	100.00	

Table of VSWR Conversions

VSWR to Return Loss		VSWR to Return Loss	
VSWR	Return Loss, dB	VSWR	Return Loss, dB
1.01	46.06	1.23	19.73
1.02	40.09	1.24	19.40
1.03	36.61	1.25	19.08
1.04	34.15	1.26	18.78
1.05	32.26	1.27	18.49
1.06	30.71	1.28	18.22
1.07	29.42	1.29	17.95
1.08	28.30	1.30	17.69
1.09	27.32	1.35	16.64
1.10	26.44	1.40	15.56
1.11	25.66	1.45	14.72
1.12	24.94	1.50	13.98
1.13	24.29	1.55	13.32
1.14	23.69	1.60	12.74
1.15	23.13	1.65	12.21
1.16	22.61	1.70	11.73
1.17	22.12	1.75	11.29
1.18	21.66	1.80	10.88
1.19	21.23	1.85	10.51
1.20	20.83	1.90	10.16
1.21	20.44	1.95	9.84
1.22	20.08	2.00	9.54

Wavelength	Frequency
100 km	3 kHz
10 km	VLF 30 kHz
1 km	LF 300 kHz
100 m	MF 3 MHz
10 m	HF 30 MHz
1 m	VHF 300 MHz
10 cm	UHF 3 GHz
1 cm	SHF 30 GHz
1 mm	EHF 300 GHz

$\lambda = \frac{c}{f}$
 c speed of light 3×10^8 m/s
 λ wavelength
 f frequency

Useful Design Formulas

Characteristic Impedance

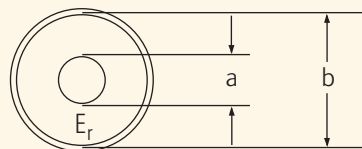

$Z_0 = 60 V_p \ln \frac{b}{a}$ (ohms)

(In all these equations, V_p is expressed as a fraction <1.)

Velocity of Propagation

$V_p = \frac{1}{\sqrt{E_r}}$

Capacitance

C (pF/ft) = $\frac{16.97}{V_p^2 \ln \frac{b}{a}}$

Dielectric Constant

$E_r = \frac{1}{V_p^2}$

Cutoff Frequency

$f_{co} \approx \frac{7.5V_p}{(a+b)}$

(a, b in inches; f_{co} in GHz)

Delay

time $t = \frac{1.016}{V_p}$ (ns/ft); or $t = \frac{3.33}{V_p}$ (ns/m)

COBHAM

The most important thing we build is trust

Cobham Antenna Systems

11 Continental Drive

Exeter NH 03833

(603) 775-5200

www.cobham.com

Rev 03-13