



Shipboard Cooling—Heat Exchanger/Fan Assembly

DESCRIPTION

AMETEK Rotronは、船舶用の液体冷却用熱交換器アセンブリをユーザーのご要望する電圧、熱交換レート、筐体サイズ、MILグレード環境要求などに応じてカスタマイズ致します。これらのユニットは、厳しい動作環境で熱を放散するように設計されています。熱交換器ファンアセンブリは耐久性のあるアルミニウムシャーシ内に封入され、船の給水を利用する電子ラックから熱を放散します。

19" Rack Unit

Dimensions: 19" W x 10.5" H x 19.25" D
(48.26 x 26.67 x 48.90 cm)

Cooling Capacity: 7 kilowatts

Power Requirements: 115VAC, 60hz, 1Φ
12.5A

Unit Weight: 80 lbs

Features

- Copper-nickel core
- 2 Rotron MAXIAX 8 vaneaxial blower
- Low Speed Warning Detector



19" Rack Unit

Dimensions: 19" W x 7" H x 17" D
(48.26 x 17.78 x 43.18 cm)

Cooling Capacity: 2.5 kilowatts

Power Requirements: 115VAC, 60hz, 1Φ
5.2A

Unit Weight: 45 lbs

Features

- Copper-nickel core
- 2 Rotron MAXIAX 5 vaneaxial blowers
- Low Speed Warning Detector



AMETEK Rotron El Cajon specializes in custom thermal management systems. Our assemblies can be customized for different input voltages, heat transfer rates, mounting and packaging options, and mil-grade environmental requirements.

For more than 60 years, AMETEK Rotron has successfully supported some of the most stringent programs and installations. Its products are specifically designed to operate efficiently, effectively and reliably in harsh environments and demanding applications.



SALES
474 Raleigh Ave • El Cajon, CA 92020 U.S.A.
Tel: +1 619-593-7400 • Fax: +1 619-593-7774
milingquiries@ametek.com



www.rottron.com



AMETEK Rotron
Military & Aerospace Products



Shipboard Cooling—Heat Exchanger/Fan Assembly

19" Rack Unit

Dimensions: 19" W x 7" H x 19" D
(48.26 x 17.78 x 48.26 cm)

Cooling Capacity: 5 kilowatts

Power Requirements: 28VDC, 650 watt

Unit Weight: 75 lbs

Features

- Copper-nickel core
- 2 Rotron MAXIAX 5.75 vaneaxial blowers
- Low Speed Warning Detector
- Fan speed control



19" Rack Unit

Dimensions: 19" W x 9.5" H x 20" D
(48.26 x 24.13 x 50.8 cm)

Cooling Capacity: 5.4 kilowatts

Power Requirements: 115VAC, 60hz, 3Φ
11A

Unit Weight: 84 lbs

Features

- Copper-nickel core
- Internal Rotron blower assembly
- Low speed warning detector



Rack Unit

Dimensions: 23" W x 5.25" H x 21" D
(58.42 x 13.25 x 53.34 cm)

Cooling Capacity: 3.2 kilowatts

Power Requirements: 28VDC, 180 watt

Unit Weight: 29 lbs

Features

- Copper-nickel core
- 4 Rotron Propimax tubeaxial blowers
- EMI filters



AMETEK Rotron El Cajon specializes in custom thermal management systems. Our assemblies can be customized for different input voltages, heat transfer rates, mounting and packaging options, and mil-grade environmental requirements.

For more than 60 years, AMETEK Rotron has successfully supported some of the most stringent programs and installations. Its products are specifically designed to operate efficiently, effectively and reliably in harsh environments and demanding applications.



SALES
474 Raleigh Ave • El Cajon, CA 92020 U.S.A.
Tel: +1 619-593-7400 • Fax: +1 619-593-7774
milingquiries@ametek.com



www.rottron.com



AMETEK Rotron
Military & Aerospace Products



Shipboard Cooling—Heat Exchanger/Fan Assembly

Air Cooling Unit

Dimensions: 80" W x 25" H x 22" D
(202.57 x 63.5 x 56.21 cm)

Cooling Capacity: 40 kilowatts

Power Requirements: 450VAC, 60hz, 3Φ, 11A

Unit Weight: 711 lbs

Features

- Copper-nickel core
- 4 Rotron MAXIAX vaneaxial blowers
- Water flow sensor
- Actuated flapper valves



Air Cooling Unit

Dimensions: 18" W x 11" H x 12.5" D
(45.72 x 27.94 x 31.75 cm)

Cooling Capacity: 3.5 kilowatts

Power Requirements: 115AC, 60hz, 1Φ
2.5A

Unit Weight: 60 lbs

Features

- Copper-nickel core
- 2 Rotron MAXIAX 8 vaneaxial blowers
- Actuated flapper valves



AMETEK Rotron El Cajon specializes in custom thermal management systems. Our assemblies can be customized for different input voltages, heat transfer rates, mounting and packaging options, and mil-grade environmental requirements.

For more than 60 years, AMETEK Rotron has successfully supported some of the most stringent programs and installations. Its products are specifically designed to operate efficiently, effectively and reliably in harsh environments and demanding applications.



SALES
474 Raleigh Ave • El Cajon, CA 92020 U.S.A.
Tel: +1 619-593-7400 • Fax: +1 619-593-7774
milingquiries@ametek.com



www.rottron.com



AMETEK Rotron
Military & Aerospace Products



Shipboard Cooling—Heat Exchanger/Fan Assembly

Air Cooling Unit

Dimensions: 23" W x 13" H x 11" D
(58.42 x 33.02 x 27.94 cm)

Cooling Capacity: 14 kilowatts

Power Requirements: 28VDC, 16A

Unit Weight: 140 lbs

Features

- Copper-nickel core
- 4 Rotron MAXIAX 5.75 vaneaxial blower with flapper valves



Air Cooling Unit

Dimensions: 18.5" W x 8.5" H x 11" D
(46.99 x 21.59 x 27.94 cm)

Cooling Capacity: 3.5 kilowatts

Power Requirements: 115VAC, 60hz, 3Φ
200 watts

Unit Weight: 45 lbs

Features

- Copper-nickel core
- 2 Rotron MAXIAX 8 vaneaxial blowers



AMETEK Rotron El Cajon specializes in custom thermal management systems. Our assemblies can be customized for different input voltages, heat transfer rates, mounting and packaging options, and mil-grade environmental requirements.

For more than 60 years, AMETEK Rotron has successfully supported some of the most stringent programs and installations. Its products are specifically designed to operate efficiently, effectively and reliably in harsh environments and demanding applications.



SALES
474 Raleigh Ave • El Cajon, CA 92020 U.S.A.
Tel: +1 619-593-7400 • Fax: +1 619-593-7774
milingquiries@ametek.com

AMETEK[®]

www.rottron.com



AMETEK Rotron
Military & Aerospace Products



Shipboard Cooling—Heat Exchangers

DESCRIPTION

AMETEK Rotronのエンジニアリンググループは熱交換器で長い歴史と経験を持ちます。当社の熱専門家は、冷却能力、空気側および流体側の条件、気流および環境用途に合わせて熱交換器をチューブライフリングおよびフィンパターンの開発も含めて設計致します。サイズ、重量、材料、およびコスト面で、最適な熱交換器をご提案致します。

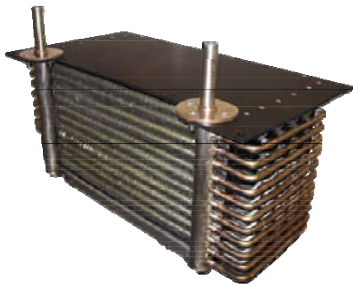

Dimensions:

24.5" W x 15" H x 13" D
(62.23 x 38.1 x 33.02 cm)

Capacity:

14 kilowatts

Copper-nickel core

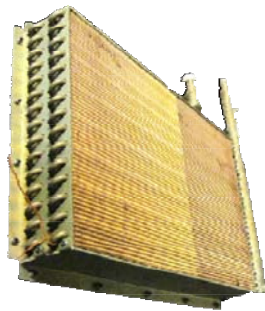

Dimensions:

24.25" W x 17" H x 3.75" D
(61.60 x 43.18 x 9.53 cm)

Capacity:

22 kilowatts

Copper-nickel core



Dimensions:

26" W x 15.25" H x 11.5" D
(66.04 x 38.74 x 29.21 cm)

Capacity:

29 kilowatts

Copper-nickel core

AMETEK Rotron El Cajon specializes in custom thermal management systems. Our assemblies can be customized for different input voltages, heat transfer rates, mounting and packaging options, and mil-grade environmental requirements.

For more than 60 years, AMETEK Rotron has successfully supported some of the most stringent programs and installations. Its products are specifically designed to operate efficiently, effectively and reliably in harsh environments and demanding applications.



SALES
474 Raleigh Ave • El Cajon, CA 92020 U.S.A.
Tel: +1 619-593-7400 • Fax: +1 619-593-7774
milingquiries@ametech.com



www.rottron.com



AMETEK Rotron
Military & Aerospace Products



Shipboard Cooling—Blowers

DESCRIPTION

AMETEK Rotronは、船舶用のカスタムエアフローユニットと送風機（ブロワ）を製造しています。典型的なブロワには金属筐体内にモーターとインペラが含まれており、スイッチ、センサ、コネクタ、およびサウンドダンピングなどの機能を備えています。



Dimensions: 21" W x 11" H x 14" D
(53.34 x 27.94 x 35.56 cm)

Airflow: 240 cfm @ 0.5 in. w.g.

Power Requirements: 115VAC, 60hz, 3Φ
12.5A

Unit Weight: 25 lbs

Features: Airflow switch, sound dampening, air filter

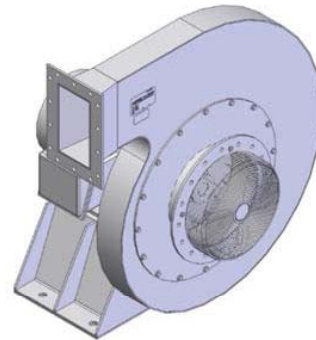

Dimensions: 33" W x 32" H x 21" D
(83.82 x 81.28 x 53.34 cm)

Airflow: 930 cfm @ 14 in. w.g.

Power Requirements: 440VAC, 60hz, 3Φ

Unit Weight: 245 lbs

AMETEK Rotron El Cajon specializes in custom thermal management systems. Our assemblies can be customized for different input voltages, heat transfer rates, mounting and packaging options, and mil-grade environmental requirements.

For more than 60 years, AMETEK Rotron has successfully supported some of the most stringent programs and installations. Its products are specifically designed to operate efficiently, effectively and reliably in harsh environments and demanding applications.



SALES
474 Raleigh Ave • El Cajon, CA 92020 U.S.A.
Tel: +1 619-593-7400 • Fax: +1 619-593-7774
milingquiries@ametek.com

AMETEK[®]

www.rottron.com



AMETEK Rotron
Military & Aerospace Products



Shipboard Heating

DESCRIPTION

いくつかのアプリケーションでは、コンポーネントまたはスペースを加熱するためにエアームーバーが使用されており、これらを統合できます。技術を1つのシステムに統合します。各コンポーネント、サーモスタット、リレー、入/切コントロールなども追加する事ができ、PTC（加熱保護）または抵抗加熱を利用します。

Bay Heater

Dimensions: 26" W x 9" H x 23.5" D
(66.04 x 22.86 x 59.69 cm)

Heating Capacity: 8 kilowatts

Power Requirements: 440VAC, 60hz, 3Φ

Unit Weight: 100 lbs

Features

- Fin strip heaters
- 2 Rotron MAXIAX 8 vaneaxial blower with check valves
- Thermostat/relay control



AMETEK Rotron El Cajon specializes in custom thermal management systems. Our assemblies can be customized for different input voltages, heat transfer rates, mounting and packaging options, and mil-grade environmental requirements.

For more than 60 years, AMETEK Rotron has successfully supported some of the most stringent programs and installations. Its products are specifically designed to operate efficiently, effectively and reliably in harsh environments and demanding applications.



SALES
474 Raleigh Ave • El Cajon, CA 92020 U.S.A.
Tel: +1 619-593-7400 • Fax: +1 619-593-7774
milingquiries@ametek.com

AMETEK®

www.rottron.com