



The MIL-XTM™ Series Fan

AMETEK Rotron MIL-XTM™ Series, “Extreme Performance” DC Tubeaxial Fan

The AMETEK Rotron MIL-XTM™ Series Tubeaxial Fan sets new performance standard for electronics cooling, ventilation and ECS Systems. The MIL-XTM™ has ruggedness and reliability for mission and personnel critical applications.



Standard Features

- Soft-start current in-rush limiting via acceleration control
- Reverse polarity protection
- Over voltage protection
- Locked rotor shut-down with auto re-start
- ESD hardened
- Cast aluminum venturi
- Advanced composite propeller material
- Tested and meets MIL-S-901 shock test
- Ambient temperature range: -54C to +85C
- Steady state voltage range: 22 to 32 VDC
- Compliant to DFARS Specialty Metals Clauses
- Best in class Fan efficiency

Optional Features

- Round or Flatted Case
- Fan performance sensor (FPS)
- Low speed warning detector (LSWD)
- Analog speed control
- Fan enable signal
- Closed-loop speed control
- Custom finishes available
- Mounting options: through holes or threaded inserts
- Finger Guard: P/N 508370000
- EMI Filter
- MS Connector attached or via pigtail assembly
- Immersion protection

Qualification Summary

Base Model MIL-XTM™ P/N 012513000 has passed the following tests:

High Temperature	MIL-STD-810F Meth. 501.4, Proc. I, II
Low Temperature	MIL-STD-810F Meth. 502.4, Proc. I, II
Temperature Variation	MIL-STD-810F Meth 501.4 & 502.1, Proc. II
Thermal Shock	MIL-STD-202G Meth. 107G
Thermal Power Cycling	4,000 on/off cycles at specified temperature variations
Cold Start	MIL-B-28873, 3.6.1
Magnetic Effect	RTCA/DO-160F Sec. 15.0, Cat. Z
Vibration	MIL-STD-810F Meth. 514.5, Proc. 1, Cat. 24 Fig 514.5C-17

Shock	MIL-STD-810F Meth. 516.5, Proc. I, Fig. 5.16.5-10
Voltage Transient	MIL-STD-704E Table II, Fig. 9 & 11
Acoustic	ISO 3741
Humidity	MIL-STD-810F Meth. 507.4
Salt Fog	MIL-STD-810F Meth. 509.4
Sand & Dust	MIL-STD-810F Meth. 510.4, Proc. I, II
Driving Rain	MIL-STD-810C Meth. 506.1, Sec. 3, Proc. 3.1-1
High Impact Shock	MIL-S-901D Cat. Lightweight, Grade B, Class I, Type C

Specifications subject to change without notice



AEROSPACE & DEFENSE

Rotron

www.rottron.com

E-mail: milinqury@ametek.com

Tel: (845) 679-1361

Fax: (845) 679-1870

55 Hasbrouck Lane

Woodstock, NY, 12498 USA



Rotron / Airscrew



Nominal Data Specific to 7,500 RPM Base Model

Part Number	Input Voltage	Speed	Running Current	Starting Current	Max Ambient	Weight	Noise @ 1.75 IWG	Fan Efficiency
012513000	28 VDC	7,500 RPM	4.1 Amps	8.5 Amps	85C	2.53 lbs	82 dBA	Up to 45%

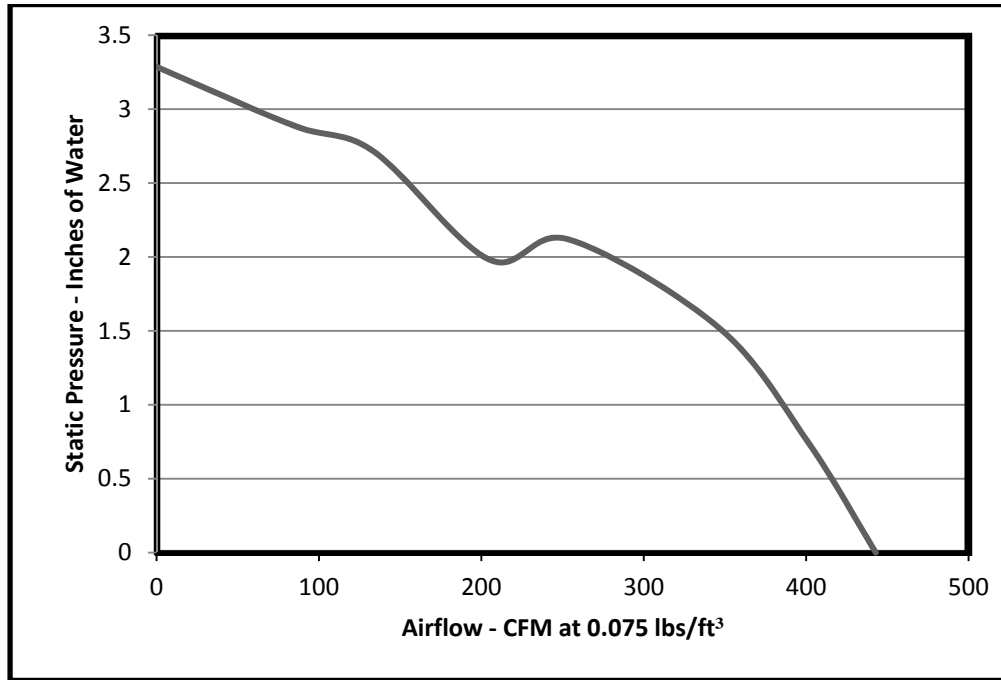

Performance Curve

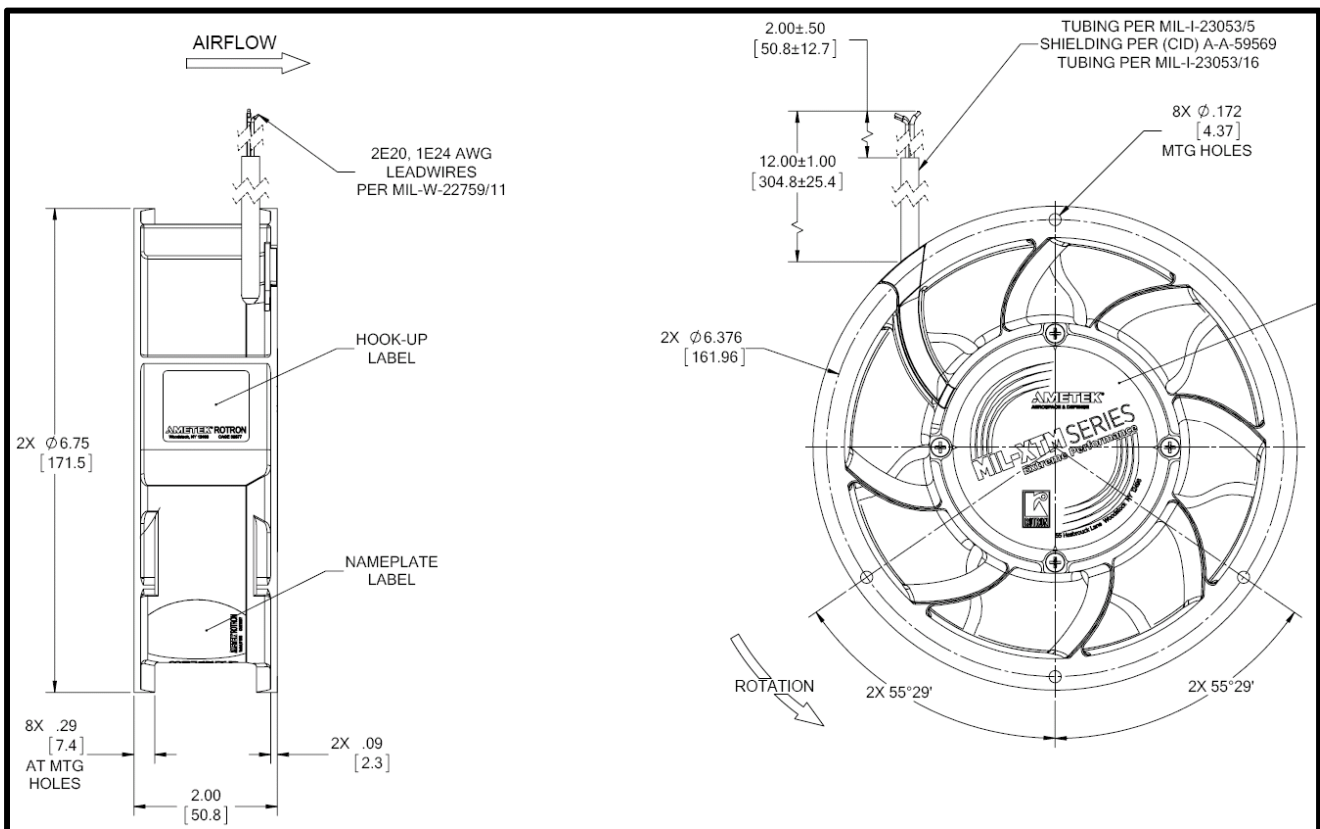

Outline Drawing; Part Number 012513000